

MICROSCAN®

MS-Q Imager User's Manual



Copyright and Disclaimer

Copyright ©2009

Microscan Systems, Inc.,
1201 S.W. 7th Street, Renton, WA, U.S.A. 98057
(425) 226-5700 FAX: (425) 226-8682

ISO 9001:2000 Certification No. 06-1080
Issued by TÜV USA

All rights reserved. The information contained herein is proprietary and is provided solely for the purpose of allowing customers to operate and/or service Microscan manufactured equipment and is not to be released, reproduced, or used for any other purpose without written permission of Microscan.

Throughout this manual, trademarked names might be used. We state herein that we are using the names to the benefit of the trademark owner, with no intention of infringement.

Windows® Operating System is a registered trademark of Microsoft Corporation.

Bluetooth® Wireless Technology is a registered trademark of Bluetooth SIG.

Disclaimer

The information and specifications described in this manual are subject to change without notice.

Latest Manual Version

For the latest version of this manual, see the Download Center on our web site at:
www.microscan.com.

Technical Support

For technical support, email: helpdesk@microscan.com.

Microscan Systems, Inc.

Renton Headquarters

1201 S.W. 7th St.
Renton, WA 98057-1213
USA
Tel: 425.226.5700 / 800.762.1149
Fax: 425.226.8250

Nashua Office

486 Amherst St.
Nashua, NH 03063
USA
Tel: 603.598.8400
Fax: 603.577.5947

Microscan Europe

Tel: 011 31 172 423360
Fax: 011 31 172 423366

Microscan Asia Pacific

Tel: 65 6846 1214
Fax: 65 6846 4641

Microscan Limited Warranty Statement and Exclusions

What Is Covered?

Microscan Systems Inc. warrants to the original purchaser that products manufactured by it will be free from defects in material and workmanship under normal use and service for a period of one year from the date of shipment. This warranty is specifically limited to, at Microscan's sole option, repair or replacement with a functionally equivalent unit and return without charge for service or return freight.

What Is Excluded?

This limited warranty specifically excludes the following: (1) Any products or parts that have been subject to misuse, neglect, accident, unauthorized repair, improper installation, or abnormal conditions or operations; (2) Any products or parts that have been transferred by the original purchaser; (3) Customer misadjustment of settings contrary to the procedure described in the Microscan Systems Inc. owners manual; (4) Upgrading software versions at customer request unless required to meet specifications in effect at the time of purchase; (5) Units returned and found to have no failure will be excluded; (6) Claims for damage in transit are to be directed to the freight carrier upon receipt. Any use of the product is at purchaser's own risk. This limited warranty is the only warranty provided by Microscan Systems Inc. regarding the product. Except for the limited warranty above, the product is provided "as is." To the maximum extent permitted by law, this express warranty excludes all other warranties, express or implied, including but not limited to, implied warranties of merchantability and. Technical support questions may be directed to: helpdesk@microscan.com. Register your product with Microscan: www.microscan.com/register. Microscan Systems Inc. does not warrant that the functions contained in the product will meet any requirements or needs purchaser may have, or that the product will operate error free, or in an uninterrupted fashion, or that any defects or errors in the product will be corrected, or that the product is compatible with any particular machinery.

Limitation of Liability

In no event shall Microscan Systems Inc. be liable to you or any third party for any special, incidental, or consequential damages (including, without limitation, indirect, special, punitive, or exemplary damages for loss of business, loss of profits, business interruption, or loss of business information), whether in contract, tort, or otherwise, even if Microscan Systems Inc. has been advised of the possibility of such damages. Microscan Systems Inc.'s aggregate liability with respect to its obligations under this warranty or otherwise with respect to the product and documentation or otherwise shall not exceed the amount paid by you for the product and documentation. Some jurisdictions do not allow the exclusion or limitation of incidental or consequential damages or limitations on an implied warranty, so the above limitation or exclusion may not apply to you. This warranty gives you specific legal rights, and you may also have other rights which may vary from state to state.

Tel: 425.226.5700 | Fax: 425.226.8250 | helpdesk@microscan.com

Table of Contents

Chapter 1	Quick Start	
	Check Required Hardware	1-2
	Assemble the Imager	1-3
	USB Interface	1-6
	PS/2 Interface	1-7
	RS-232 Interface	1-8
	Bluetooth Interface	1-9
	Batch/Battery Interface	1-10
	Install ESP	1-11
	Select Model	1-12
	Select Protocol and Connect to Imager	1-13
Chapter 2	Using ESP	
	EZ Mode	2-2
	Application Mode	2-3
	Tree Controls	2-4
	Menu Toolbar	2-5
	Send/Receive	2-14
Chapter 3	Basic Operations	
	Step 1 Practice Targeting	3-2
	Step 2 Determine Optimum Position	3-3
	Step 3 Select Quadrus Only or Standard Mode	3-4
	Step 4 Select Adaptive or Fixed Mode	3-5
	Step 5 Complete Configuration	3-6
	Trigger and Button Programming	3-7
	USB Battery Charge Mode	3-8
Chapter 4	Communications	
	Communications by ESP	4-2
	Communications Overview	4-3
	USB Interface	4-4
	PS/2 Interface	4-5
	RS-232 Interface	4-6
	Bluetooth Interface	4-8
	Batch/Battery	4-16
	Preamble	4-20
	Postamble	4-21
	Preamble and Postamble by ESP	4-22
	Keyboard Mapping	4-23
	Text Commands	4-24
	Time Stamp	4-25
	Other Communications Settings in ESP	4-26
Chapter 5	Symbologies	
	Symbologies by ESP	5-2

Aztec.....	5-3
Codabar	5-4
Codablock F	5-5
Code 11	5-6
Code 39	5-7
Code 93	5-9
Code 128.....	5-10
Composite	5-11
Data Matrix	5-12
Interleaved 2 of 5.....	5-13
Maxicode	5-14
Matrix 2 of 5.....	5-15
MicroPDF417.....	5-16
MSI Plessey.....	5-17
NEC 2 of 5.....	5-18
PDF417	5-19
Pharmacode	5-20
Postal Symbologies	5-22
QR Code.....	5-24
DataBar Symbologies.....	5-25
UPC/EAN/JAN.....	5-26
Symbology Identifier	5-27
Chapter 6 I/O Parameters	
I/O Parameters by ESP	6-2
Laser Target	6-3
Illumination	6-4
MS-Q Operational Feedback.....	6-5
Trigger and Button Programming	6-6
Beep and Vibrate Settings.....	6-8
Automatic Gain Control (AGC)	6-9
LightRay Optics	6-11
Chapter 7 Advanced Operations	
Dual Optics	7-2
VGA and Megapixel Settings.....	7-3
Select Region of Interest	7-4
Set Targeting Zone Tolerances	7-5
IP Modes	7-6
Trigger Optimization	7-7
Trigger Optimization by ESP	7-15
Continuous Operations.....	7-18
Symbol Background	7-20
Set Decode Time.....	7-21
Button Stay-Down Time.....	7-22
Mirroring	7-23
Motion Detection.....	7-24

Table of Contents

Auto White Balance	7-25
Symbol Readability Index	7-26
Chapter 8 Terminal	
Terminal View	8-2
Find	8-3
Send	8-4
Macros	8-5
Terminal Right-Click Menu	8-6
Terminal Dropdown Menu	8-7
Chapter 9 Utilities	
Image Upload	9-2
Device Control	9-3
Differences from Default	9-4
Firmware	9-5
Bluetooth	9-7
Advanced	9-8
Chapter 10 Unique Item Identifiers	
UII Overview	10-2
Non-UII Characters	10-3
UII Mode Features	10-4
Error Messaging	10-6
Valid Formats	10-8
Appendices	
Appendix A General Specifications	A-2
Appendix B Electrical Specifications	A-4
Appendix C Configuration Symbols	A-7
Appendix D Configuration Symbol Reference List	A-41
Appendix E Hardware Default and Manual Battery Recharge	A-58
Appendix F MS-Q Quadrus Secure with Image Lock	A-61
Appendix G MS-Q Protective Jacket	A-62
Appendix H MS-Q Battery Charger	A-63
Appendix I MS-Q Bluetooth Modem	A-65
Appendix J MS-Q Maintenance	A-68

About the MS-Q Imager

The MS-Q Imager, with point-and-click triggering, can read both 1D and 2D symbols and transfer (or buffer and transfer later) decoded data in both cable and wireless configurations. The MS-Q Imager is available in USB, RS-232, and PS/2 cabled options, a Batch option, and a Bluetooth option.

The MS-Q uses dual optics (near field and far field in the same array), a 1.3 million pixel CMOS sensor, and a 400 MHz processor. The imager automatically discriminates between all major 1D and 2D symbologies.

The Quadrus® model of the MS-Q Imager features added functionality that allows users to optimize the readability of 2D direct part marks.

Both the Quadrus and Basic models of the MS-Q Imager can be configured by reading Data Matrix symbols encoded with a wide variety of setup commands, or by using Microscan's **ESP®** Software.

Rev 6 Hardware

MS-Q hardware has been updated to include a new image sensor. The new hardware is referred to in this documentation as **Rev 6**. Imagers with Rev 6 hardware are clearly identified on the label inside the battery bay.

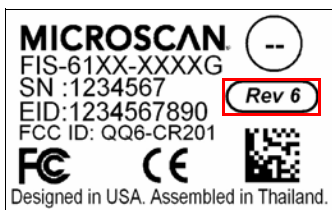

About This Manual

This manual provides complete information on setting up, installing, and configuring the MS-Q Imager. The chapters are presented in the order in which the imager would be assembled, configured, and optimized.

Highlighting

Cross-references and web addresses are highlighted in **blue bold**.

References to **ESP**, its toolbar headings (Communications, Symbologies, I/O Parameters, etc.) and menu headings are highlighted in **Bold Initial Caps**.

Product Labels

The following labels are located on the MS-Q Quadrus Imager:

(Top)

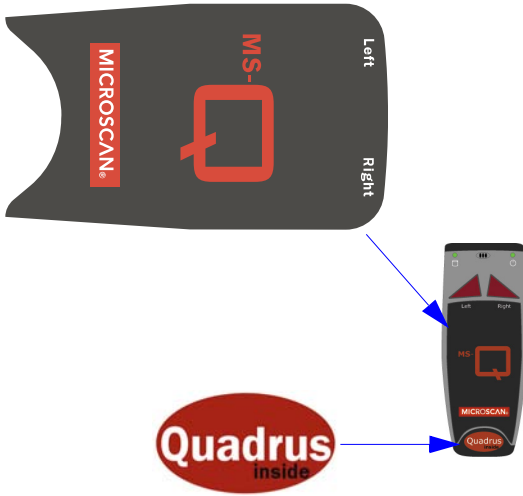

(Bottom)



The following labels are located on the MS-Q Basic Imager:

(Top)

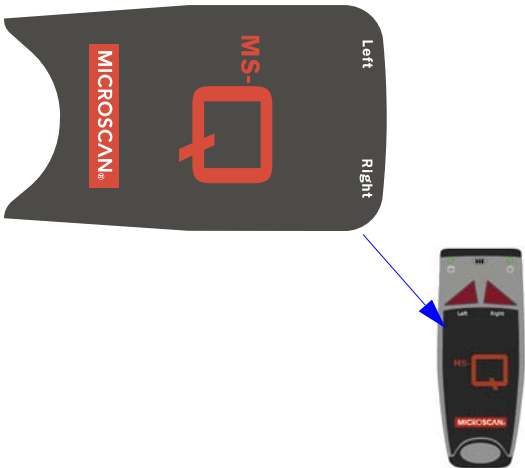

(Bottom)



Statement of Agency Compliance



The MS-Q has been tested for compliance with FCC regulations and was found to be compliant with all applicable FCC Rules and Regulations.

IMPORTANT NOTE: To comply with FCC RF exposure compliance requirements, this device must not be co-located or operate in conjunction with any other antenna or transmitter.

CAUTION: Changes or modifications not expressly approved by the party responsible for compliance could void the user's authority to operate the equipment.



The MS-Q has been tested for compliance to CE (Conformité Européenne) standards and guidelines and was found to conform to applicable CE standards, specifically the EMC requirements EN 55024, ESD EN 61000-4-2, Radiated RF Immunity EN 61000-4-3, ENV 50204, EFT EN 61000-4-4, Conducted RF Immunity EN 61000-4-6, EN 55022, Class B Radiated Emissions, and Class B Conducted Emissions.

The MS-Q can be set to use targeting lasers. The MS-Q's targeting laser emits Class 2M radiation outside of the product per IEC 60825-1. Class 2M Laser/LED product. Do not stare into the beam or view directly with optical instruments.

The MS-Q has been tested by an independent electromagnetic compatibility laboratory in accordance with the applicable specifications and instructions.



Laser/LED Radiation

Wavelength: <1mW

Maximum Output: 650-700 nm

Laser Pulse Duration: 0.977 mSec.

LED Pulse Duration: 0.255 uSec.

Statement of RoHS Compliance

All Microscan readers with a 'G' suffix in the FIS number are RoHS-Compliant. All compliant readers were converted prior to March 1, 2007. All standard accessories in the Microscan Product Pricing Catalog are RoHS-Compliant except 20-500013-01 and 98-000039-02. These products meet all the requirements of the European Parliament and the Council of the European Union for RoHS compliance. In accordance with the latest requirements, our RoHS-compliant products and packaging do not contain intentionally added Deca-BDE, Perfluorooctanes (PFOS) or Perfluorooctanoic Acid (PFOA) compounds above the maximum trace levels. To view the documents stating these requirements, please visit:

<http://eur-lex.europa.eu/LexUriServ/LexUriServ.do?uri=CELEX:32002L0095:EN:HTML>

and

<http://eur-lex.europa.eu/LexUriServ/LexUriServ.do?uri=OJ:L:2006:372:0032:0034:EN:PDF>

Please contact your sales manager for a complete list of Microscan's RoHS-Compliant products.

This declaration is based upon information obtained from sources which Microscan believes to be reliable, and from random sample testing; however, the information is provided without any representation of warranty, expressed or implied, regarding accuracy or correctness. Microscan does not specifically run any analysis on our raw materials or end product to measure for these substances.

The information provided in this certification notice is correct to the best of Microscan's knowledge at the date of publication. This notice is not to be considered a warranty or quality specification. Users are responsible for determining the applicability of any RoHS legislation or regulations based on their individual use of the product.

Warning and Caution Summary



A warning label (see above) is located on the underside of the MS-Q near the battery locking mechanism.

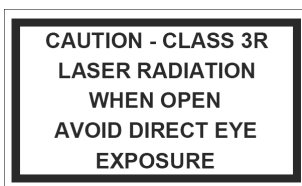

Microscan voids product warranty if the hard case has been opened or tampered with in any way. Opening the case may put the user at risk of laser radiation exposure (Class 3R). A second warning label (see above) is placed within the casing structure.

CAUTION: Use of controls or adjustments, or performance of procedures other than those specified herein may result in hazardous radiation exposure.

In addition, a CB Test Certificate has been issued by the National Certification Board (NCB) indicating that the MS-Q meets all safety and quality standards in accordance with IEC 60950-1:2001, First Edition.

1 Quick Start

Contents

Check Required Hardware	1-2
Assemble the Imager.....	1-3
USB Interface	1-6
PS/2 Interface.....	1-7
RS-232 Interface	1-8
Bluetooth Interface	1-9
Batch/Battery Interface.....	1-10
Install ESP.....	1-11
Select Model.....	1-12
Select Protocol and Connect to Imager.....	1-13

This section is designed to get your MS-Q Imager up and running quickly so you can get a sense of its capabilities and test sample symbols. Detailed setup information for configuring the imager for your specific application can be obtained in the subsequent sections.

Your interface type will determine how data is received by your host. When sending data by USB or PS/2, you must open a text editor in your host computer. When sending data serially, you must use a terminal program such as HyperTerminal or **ESP's Terminal** view (RS-232 only).

Check Required Hardware

Parts List for MS-Q Imagers with Cabled Handle (H2):

- One MS-Q Imager
- One H2 Handle
- One 6 ft. USB cable (Quadrus models only)
Note: PS/2 and RS-232 cables are optional and must be purchased separately.
- One Cable Clamp
- Two 2-56 x 5/16" screws, hex head, 1.5 inch-pounds (for Cable Clamp)
- Two 2-56 x 3/16" screws, hex head, 1.5 inch-pounds (for securing underside of imager body to H2 Handle)
- Two 2-56 x 3/16" screws, hex head, 1.0 inch-pounds (for flexible 8-pin DIN connector at back of handle)

Parts List for MS-Q Imagers with 1950 mAH Battery Handle (BH1) (Rev 5 and earlier only):

- One MS-Q Imager
- One BH1 Handle
- One 6 ft. USB cable (Quadrus models only)
Note: PS/2 and RS-232 cables are optional and must be purchased separately.
- One Cable Clamp
- Two 2-56 x 5/16" screws, hex head, 1.5 inch-pounds (for Cable Clamp)
- Two 2-56 x 3/16" screws, hex head, 1.5 inch-pounds (for securing underside of imager body to H2 Handle)

Parts List for MS-Q Imagers with 3900 mAH Battery Handle (BH2):

- One MS-Q Imager
- One BH2 Handle
- One 6 ft. USB cable (Quadrus models only)
Note: PS/2 and RS-232 cables are optional and must be purchased separately.
- One Cable Clamp
- Two 2-56 x 5/16" screws, hex head, 1.5 inch-pounds (for Cable Clamp)
- Two 2-56 x 3/16" screws, hex head, 1.5 inch-pounds (for securing underside of imager body to H2 Handle)

Parts List for MS-Q Imagers with Original Handle (H1):

- One MS-Q Imager
- One H1 Handle
- One 6 ft. USB cable (Quadrus models only)
Note: PS/2 and RS-232 cables are optional and must be purchased separately.

Assemble the Imager

To assemble the MS-Q Imager with Cabled Handle (H2):

1. Insert the flexible connector at the back of the H2 Handle into the MS-Q's 8-pin DIN connector.



Flexible Connector

2. Snap the imager onto the H2 Handle over the battery blank. Be sure that the underside of the imager is latched at the front of the handle.



Latch

3. Secure the flexible connector at the back of the H2 Handle with the two screws provided.

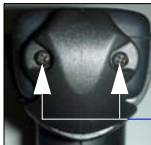

Screws

4. Secure the underside of the imager to the H2 Handle with the two screws provided.



Screws

5. Attach the cable to the bottom of the handle. Secure the cable clamp with the two screws provided.



Insert screws in the through-holes at the base of the cable clamp.

To assemble the MS-Q Imager with Battery Handle:

1. Insert the tab on the back of the battery handle into the imager's recessed slot at the base of the battery bay.



2. Snap the imager onto the battery handle over the battery. Be sure that the underside of the imager is latched at the front of the handle.

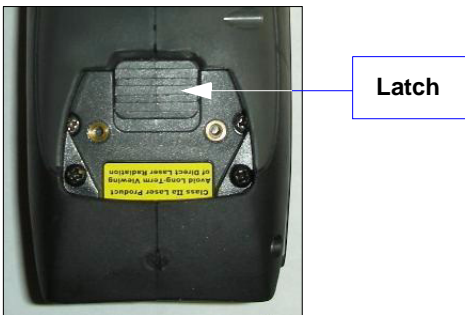

3. Secure the underside of the imager to the battery handle with the two screws provided.

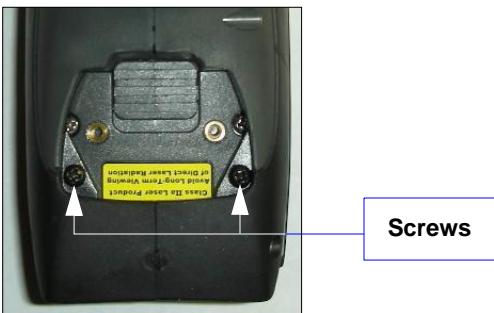

To assemble the MS-Q Imager with Original Handle (H1):

1. Slide the imager into the handle's cradle. Be sure the tabs fit into the grooves along the sides of the imager and that the handle's 8-pin DIN connector inserts completely into the back of the unit.



2. Plug the USB, PS/2, or RS-232 cable into the bottom of the handle. Plug the other end of the cable into the appropriate port on your host computer.

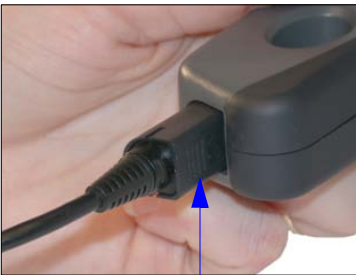

Grasp the connection housing and pull to remove. **Do not** pull directly on the cable.

USB Interface

Note: The USB interface draws its power from the host computer.

USB Configuration

Item	Description	Part Number	
		Rev 5 Hardware	Rev 6 Hardware
1	MS-Q Imager	Quadrus: FIS-6100-0030G, -0035G, -0046G Basic: FIS-6150-0020G	Quadrus: FIS-6100-0047G, -0051G, -0053G Basic: FIS-6150-0028G
2	USB Cable	Included	

Installation Steps for USB

1. Connect the USB cable (2) to the MS-Q (1).
2. Connect the USB cable (2) to the host.
You **DO NOT** need to power off your host computer.
3. Open any program in your host computer that can receive keyboard text.
4. Read the **USB Keyboard Mode** symbol below:



M134_02

USB Keyboard Mode

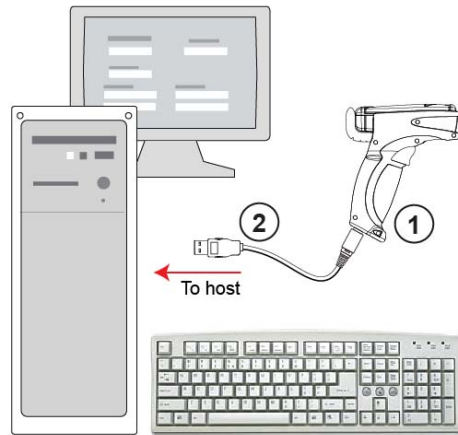

USB Configuration

5. Read the **Save Settings** symbol at the bottom of this page.

You are now ready to send data to the host.

Note: If you attempt to connect to the host via USB *and you have a battery installed*, the host will fail to recognize the imager for approximately **60 seconds**. If you connect with a battery blank installed, or if you install the battery after plugging in, no delay occurs.



Save Settings

M188_02



Default to USB

M049_03



Default to PS/2

M060_03



Clear All Data

M071_01



Clear XML Rules

M052_01

PS/2 Interface

Note: The PS/2 interface draws its power from the host computer.

PS/2 Configuration

Item	Description	Part Number	
		Rev 5 Hardware	Rev 6 Hardware
1	MS-Q Imager	Quadrus: FIS-6100-0040G, -0041G Basic: FIS-6150-0025G	Quadrus: FIS-6100-0049G Basic: FIS-6150-0030G
		60-000018-03	
2	Keyboard Wedge Cable		

Installation Steps for PS/2

1. Power-off the host and disconnect the keyboard.
2. Attach the cable (2) to the MS-Q (1).
3. Attach the keyboard connector to the keyboard cable and host computer as shown.
4. Power-on the host.
5. Read the **PS/2 Mode** symbol below:



M126_01

PS/2 Mode

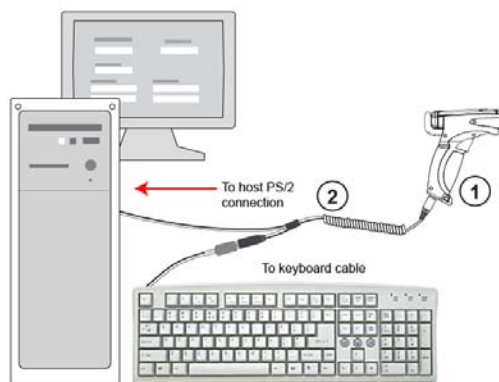

PS/2 Configuration

This connection protocol provides power to the MS-Q, and, when attached, will allow data input from both the MS-Q and the keyboard.

6. Read the **Save Settings** symbol at the bottom of this page.

You are now ready to send data to the host.

Important: The MS-Q *must* be connected to the keyboard for the imager and the keyboard to function in **PS/2 Mode**.



M188_02

Save
Settings



M049_03

Default
to USB



M060_03

Default
to PS/2



M071_01

Clear
All Data



M052_01

Clear
XML
Rules

RS-232 Interface

Note: Unlike USB and PS/2, the RS-232 interface does not draw its power from the host computer.

RS-232 Configuration

Item	Description	Part Number
1	MS-Q Imager	Quadrus: FIS-6100-XXXXG Basic: FIS-6150-XXXXG Note: For the RS-232 option, order any MS-Q FIS plus the RS-232 kit listed below.
RS-232 Kit includes:		98-000074-04 (U.S.) -05 (Europe) -06 (UK)
2	RS-232 Cable	
3	Power Supply	

Installation Steps for RS-232

1. Power-off the host computer.
2. Connect the 8-pin mini-DIN on the cable (2) to the MS-Q (1).
3. Connect the 9-pin D-sub connector to the host computer's serial port.
4. Connect the cable to the power supply.
5. Plug in the power supply (3) and power-on the host computer.
6. Start up a terminal program (such as **ESP's Terminal** view or HyperTerminal) and set to **57.6K** baud, **8** data bits, **none** parity, **2** stop bits, and **none** hardware.
7. Read the **RS-232 Default Settings Mode** symbol below.

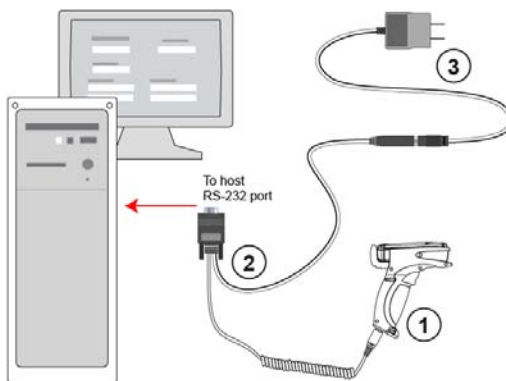

RS-232 Configuration



MS101_01

RS-232 Default Settings Mode

8. Read the **Save Settings** symbol at the bottom of this page.

You are now ready to send data to the host.



Save Settings

M188_02



Default to USB

M049_03



Default to PS/2

M060_03



Clear All Data

M071_01



Clear XML Rules

M052_01

Bluetooth Interface

Note: The USB interface draws its power from the host computer.

Note: The Microscan Bluetooth modem defaults to a USB keyboard interface, and data is displayed as if input from a keyboard.

Bluetooth Configuration

Item	Description	Part Number	
		Rev 5 Hardware	Rev 6 Hardware
1	MS-Q Imager	<i>Quadrus:</i> FIS-6100-0033G, -0034G, -0038G, -0039G, -0042G, -0043G, -0044G, -0045G <i>Basic:</i> FIS-6150-0023G, -0024G, -0026G, -0027G	<i>Quadrus:</i> FIS-6100-0050G, -0054G <i>Basic:</i> FIS-6150-0031G
2	USB Bluetooth Modem (Default option)	98-000076-10	
3	USB Cable	Included with kit	
	Note: RS-232 options also available	98-000076-07, -08, -09	

Installation Steps for Bluetooth

1. Connect the USB cable (3) from the host computer to the Bluetooth Modem (2).
You **DO NOT** need to power off your host computer.
2. Open any program in the host computer that can receive and display keyboard data.
3. Read the symbol on the Bluetooth modem's top label (2).
4. Read the **Save Settings** symbol at the bottom of this page.

You are now ready to send data to the host.

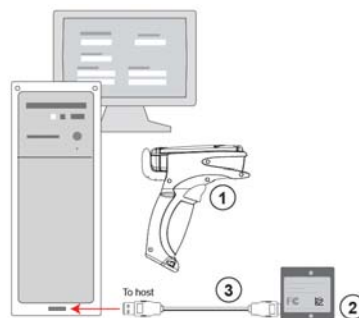

Bluetooth Configuration



M129_02

RF Two-Way Mode

Note: If you are using an older Bluetooth Modem, read the **RF Two-Way Mode** symbol above to enable wireless communication with the host computer.

Note: See [Connecting to the Bluetooth Modem via RS-232](#) for instructions on how to use the Bluetooth Modem with a serial connection.



M188_02

Save Settings



M049_03

Default to USB



M060_03

Default to PS/2



M071_01

Clear All Data



M052_01

Clear XML Rules

Batch/Battery Interface

Important: ESP does not support Batch/Battery Interface.

Overview

In **Batch Mode** a battery replaces the blank inside the MS-Q. The MS-Q is capable of reading more than 4,000 times from a single battery charge without being physically connected to the host. When you do connect (either by cable or wireless), the buffered data is transferred to the host in the manner determined by your batch setup.

Batch/Battery Configuration

Item	Description	Part Number	
1	MS-Q Imager	Rev 5 Hardware	Rev 6 Hardware
		<i>Quadrus:</i> FIS-6100-0031G, -0032G, -0036G, -0037G	<i>Quadrus:</i> FIS-6100-0048G, -0052G
		<i>Basic:</i> FIS-6150-0021G, -0022G	<i>Basic:</i> FIS-6150-0029G
2	Battery	Included	

Installation Steps for Batch/Battery

1. Insert the tab on the back of the battery handle into the imager's recessed slot at the base of the battery bay.
2. Snap the imager onto the handle over the battery. Be sure that the underside of the imager is latched at the front of the handle.
3. Secure the underside of the imager to the handle with the two screws provided.
4. Select one of the **Batch Setup** modes - **Send and Log**, or **Send and Buffer**.
5. Read symbols as required.
6. Save settings.
7. When convenient, or when the buffer is full, open any Windows-compatible program that can accept keyboard text (for USB and PS/2) or serial data (for RS-232 and Bluetooth).
8. Attach a cable or connect to Bluetooth to download buffered data.

Batch Setup

Send and Log Mode



M076_01

If you read the **Send and Log Mode** symbol to the left, all buffered data will be downloaded to the host but retained in the imager's memory whenever you connect.

Send and Buffer Mode (Default)

If you read the **Send and Buffer Mode** symbol to the right, all buffered data will be downloaded to the host and **ERASED** in the imager whenever you connect.

You must have a data collection program open before connecting in **Send and Buffer Mode** or all buffered data will be lost.



M075_01



M188_02

Save Settings

Install ESP

ESP Software can be found on the Microscan Tools CD that is packaged with the MS-Q.

1. Follow the prompts to install ESP from the CD.
2. Click on the ESP icon to run the program.



Note: ESP can also be installed from the **Download Center** at www.microscan.com.

ESP System Requirements

- 166 MHz Pentium processor (recommended)
- Windows Vista, XP, or 2000 operating system
- Internet Explorer 5.0 or higher
- 64 MB minimum RAM
- 40 MB minimum disk space

Important: The imager must be in one of the modes below to communicate with **ESP**.

USB	USB Connect Mode	
RS-232	RS-232 Connect Mode	

Select Model

When you start **ESP**, the following menu will appear:



If you need to select another model later, click **Switch Model** at the top of the screen.



1. Click the **MS-Q** button and then click **OK**. If you do not want to make this selection every time you start **ESP**, uncheck “Show this dialog at startup”.
2. Select the default reader name (**MS-Q-1**), or type a name of your choice in the **Description** text field and click **OK**.
3. Click **Yes** when this dialog appears:

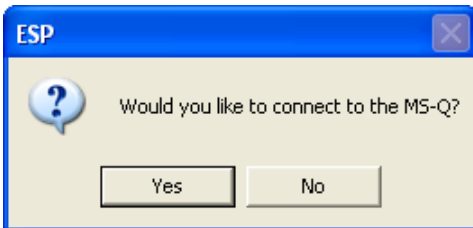

Select Protocol and Connect to Imager

RS-232

- In the **Select Protocol** dialog box, select the communications protocol you are using and click **Next**.

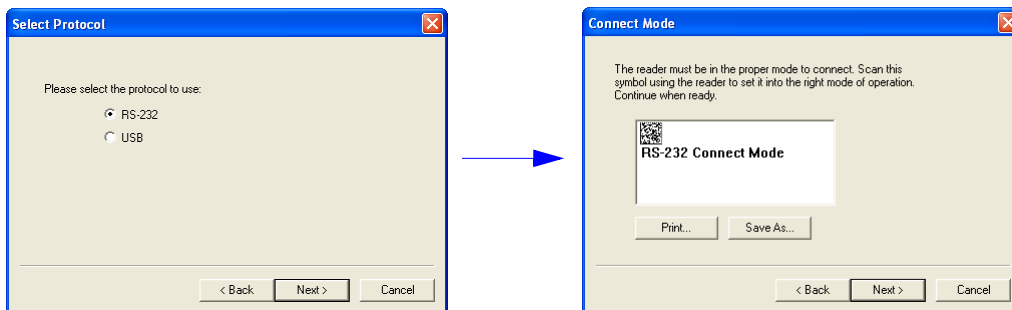

- Print the **RS-232 Connect Mode** symbol and read it with the imager to ensure that you are in the correct communications mode. Keep the printed symbol in a convenient place for future use.
- Click **Next** when you are finished.
- The **Com Port** dialog will then appear. Select which communications port you are using. If you don't see your communications port listed on the dropdown menu, select **Other**.

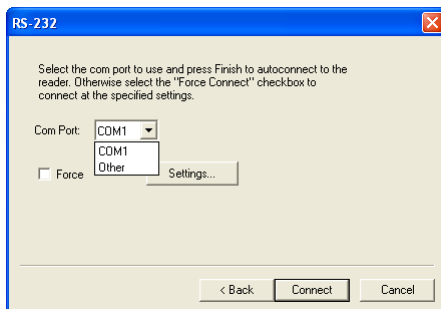

- Click **Connect**.
- When you are connected successfully, the **CONNECTED** message will appear in a green box in the status bar at the bottom right of the screen.

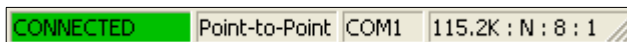

If the connection attempt fails, enable a different communications port, check your port connections, and try again. You can also check the **Force Connect** box and then click the **Connect** button.

You are now ready to configure your imager using **ESP**. Subsequent sections provide more detailed information about **ESP's** configuration options.

USB

- In the **Select Protocol** dialog box, select the communications protocol you are using and click **Next**.

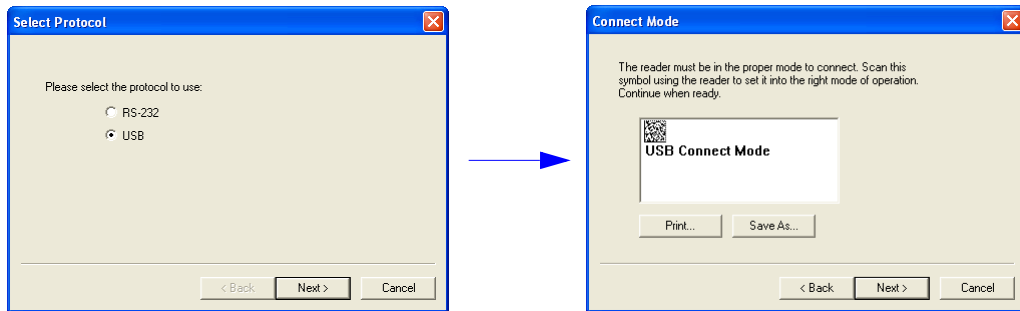

- Print the **USB Connect Mode** symbol and read it with the imager to ensure that you are in the correct communications mode. Keep the printed symbol in a convenient place for future use.
- Click **Next** when you are finished.

The following dialog will then appear:

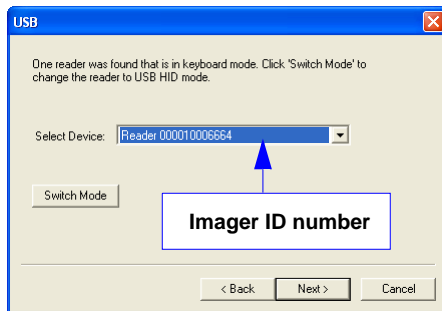

- You will see a “Reader” ID number in the **Select Device** field. Click **Next**.

Note: If the imager is in the default **USB Keyboard Mode** when you attempt to connect, the **USB Reader ID** dialog will tell you to click the **Switch Mode** button. **ESP** will attempt to switch the imager to **USB HID Mode**. Once the imager has switched modes, click **Next**.

- When you are connected successfully, the **CONNECTED** message will appear in a green box in the status bar at the bottom right of the screen.

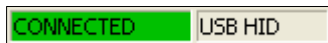

You are now ready to configure your imager using **ESP**. Subsequent sections provide more detailed information about **ESP**'s configuration options.

2 Using ESP

Contents

EZ Mode	2-2
Application Mode	2-3
Tree Controls	2-4
Menu Toolbar	2-5
Send/Receive	2-14

This section is designed to help you understand the structure and application of **ESP**.

When you open **ESP**, unless otherwise specified in the **ESP Preferences** dialog accessible from the **Options** heading on the menu toolbar, you will enter **EZ Mode** for initial setup. From there, you can enter **Application Mode (App Mode)** and access several configuration menus (**Communications**, **Read Cycle**, **Symbologies**, **I/O Parameters**, an **Imager** setup interface, a **Terminal** interface, and a **Utilities** interface).

ESP can be used to configure the MS-Q Imager in the following ways:

- **Tree Controls:** Each configuration menu contains a list of all option settings that pertain to that specific element of imager operation. For example, the **Communications** menu shows a **Communications Mode** command, and then the options **PS/2 (AT) Keyboard**, **RS-232 Serial**, **USB Keyboard**, **RF (Bluetooth)**, and **USB Native (HID)**, all of which are accessible from a dropdown menu.
- **Graphic User Interfaces:** Settings can be configured using such point-and-click tools as radio buttons, tabs, spin boxes, check boxes, and drag-and-drop functions.
- **Terminal:** **ESP**'s **Terminal** interface allows you to send configuration and utility commands directly to the imager by typing them in the provided text field.

EZ Mode

The **EZ Mode** screen is the first thing you will see when you start **ESP**. **EZ Mode** will help you get your imager up and running quickly, and will acquaint you with the **ESP** interface.

ESP - Untitled

File Model Options Connect Help

App Mode Connect Switch Model

Welcome to Easy Setup Program

Instructions For Decoding Symbol Data:
(Does not take picture)

1. Click the **Decode** button. The MS-Q is now ready to decode symbol data.
2. Point the MS-Q at a symbol and squeeze the handle trigger.
3. Move the Imager closer or farther from the symbol until you hear one beep, indicating that a good read has occurred.
4. Up to 128 characters of symbol data will be displayed in the **Symbol Data** field.

Instructions For Taking Pictures:
(Does not decode symbol data)

1. Select the appropriate option from the **Select Trigger to Take Picture** drop-down list.
2. Click the **Start** button.
3. Use the corresponding button/trigger to take a picture, move the Imager closer or farther from the symbol to test the quality of images being captured.
4. Click the **Stop** button to view or save images.

Decode Symbol Data

Decode Symbol Data

Taking Pictures

Select Trigger to Take Picture

Right Button Start

Far Field

Save Image...

Near Field

For Help, press F1.

MS-Q-1 MS-Q

The **EZ Mode** toolbar allows you to switch to **App Mode**, check your connection parameters, and to switch models.

The **Decode** button allows you to begin capturing images and displaying decoded symbol data right away.

The **Taking Pictures** dropdown menu allows you to choose which trigger will activate an image capture: **Handle Trigger**, **Right Button**, or **Left Button**.

When an image is captured, it is displayed here as a split view that shows both the **near field** and **far field** images. Double click this image to view it in a larger format. Click **Save Image** to save it to a location of your choice.

Application Mode

Application Mode gives you access to a robust configuration environment, including tree controls that let you make precise changes to operation parameters, and graphic interfaces that make configuring your imager easy and intuitive.

The screenshot shows the EZ Mode application interface. The top menu bar includes File, Model, Options, Connect, View, and Help. Below the menu is an operations bar with icons for EZ Mode, Connect, Send/Recv, Switch Model, Parameters, Imager, Terminal, and Utilities. A configuration bar below the operations bar contains tabs for Communication, Read Cycle, Symbologies, and I/O. The main window is divided into two panes: Parameters and ESP Values. The Parameters pane shows a tree view of configuration options, and the ESP Values pane shows a list of values for those options. A right-hand pane contains a form for assigning Preamble and Postamble characters, with a keyboard layout below it.

Callout boxes provide the following instructions:

- Click here to return to **EZ Mode**.
- Click on this icon to return to this view from **Utilities** or **Terminal**.
- Click here for imager button optimization, configuration, and configuration summary.
- Click these tabs to access configuration tree controls.
- Click here for **Image Upload, Batch Files, and Firmware**.
- Click here to open **Terminal**.
- Click these buttons to **Send and Receive** commands or switch reader models.
- Menu toolbar

Assign Preamble and Postamble characters using the simple interface shown above.

Note: For specific information on any of the icons shown above in the operations bar or configuration bar, see corresponding chapters in this manual.

Tree Controls

To make changes to configuration settings in the tree control menus:

The screenshot shows a 'Parameters' window with a tree view. The 'Communications' folder is expanded, showing 'Communications Mode' (USB Keyboard), 'RS232', and 'USB Keyboard Rate'. The 'RS232' folder is also expanded, showing 'Batch Mode' (Detect), 'Baud Rate' (57.6K), 'Parity' (None), 'Stop Bits' (Two*), 'Data Bits' (One), 'Keyboard Mapping' (Two*), 'Reader Auto Connect' (Enabled), and 'Reconnect Timeout' (90). The 'Stop Bits' dropdown menu is open, showing 'One' and 'Two*' options. A blue arrow points to the 'Stop Bits' dropdown, and another blue arrow points to the 'Two*' option. A third blue arrow points to the 'Communications' folder icon.

1. **Left click** on the +/- to expand or collapse the tree.
2. **Double click** on the parameter and click once in the selection box to view options.
3. Place your cursor in the selection box, scroll down to the setting you want to change and **click once** on the setting.
4. **Left click** again on the open screen to complete the selection.
5. **Right click** on the open screen and select **Save to Reader** to implement the command in the imager.

The imager must be in one of the modes below to communicate with **ESP**.

USB	USB Connect Mode	
RS-232	RS-232 Connect Mode	

Menu Toolbar

File > New

Whenever **New** is selected from the **File** menu, the default configuration of **ESP** is loaded.

Open / Save

When **Save** or **Save As** is selected, the **ESP** configuration is saved to the host computer's hard drive and available whenever the same file is selected under **Open**.

When you save menu changes to your hard drive, these changes are not saved to your imager. The diagram below shows how settings can be saved and received between **ESP** and the imager, and **ESP** and the host hard drive.

File	
New	Ctrl+N
Open...	Ctrl+O
Save	Ctrl+S
Save As...	
<hr/>	
Print...	Ctrl+P
<hr/>	
Import...	
Export...	

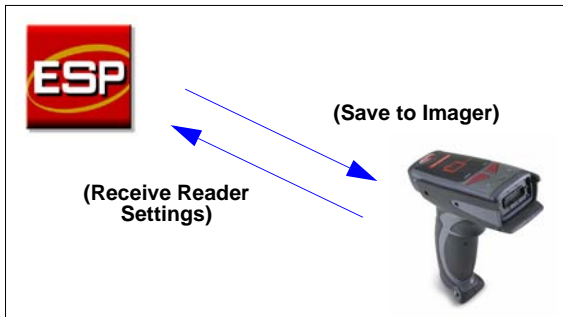

Import / Export

Import converts the ASCII settings from a text file to **ESP** configuration settings.

Export converts the active **ESP** configuration settings to an ASCII text file.

Model

The **Model** menu allows you to select between reader models. When you choose another model, the current connection with your present model will be terminated.

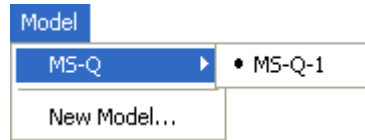

New Model

To connect to another model, select **New Model**, choose the model you want, and click **OK**. All models you have selected and enabled will continue to appear in the dropdown model menu. The **New Model** option is repeated when you click the **Switch Model** button on the top row of icons.



Options

You can use the **Options** menu to save memos and set up **ESP** preferences.

Preferences will be saved and loaded into **ESP** the next time **ESP** is opened, whether or not you save the **ESP** file to the host computer.

Preferences > General Tab

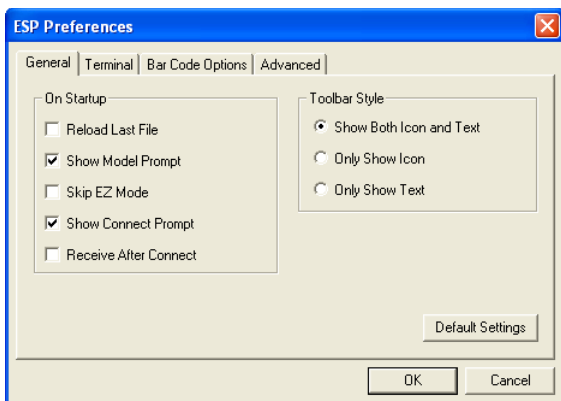

Reload Last File

At startup, reloads the last file saved to the computer.

Show Model Prompt

At startup, remembers the last connected model and displays it in the **Connecting...** dialog whenever you attempt to connect.

Skip EZ Mode

At startup, skips **EZ Mode** and opens directly in **App Mode**.

Show Connect Prompt

At startup, displays the **Would you like to connect...** prompt.

Receive After Connect

At startup, loads the imager's settings into **ESP**. (This is not recommended if you want to preserve your **ESP** settings for future use.)

Show Both Icon and Text (Default)

Sets the toolbar to display icons and names of all operations.

Only Show Icon

Sets the toolbar to display only icons representing operations, without text.

Only Show Text

Sets the toolbar to display names of operations only, without icons.

Terminal Tab

When **Show Non-Printable Characters** is checked, characters such as ‘CRLF’ will be displayed in the terminal window. When the **Enhanced Format** radio button is checked, subscript and superscript formatting is shown.

When **Display incoming data even when not in focus** is checked, data from the imager will continue to appear in the terminal even when **ESP** is not the top window on the host computer’s screen.

When **Enable Echo** is checked, the terminal window displays user-entered data.

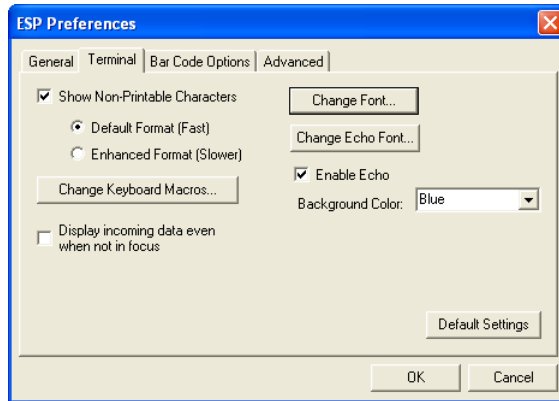

Change Keyboard Macros

Clicking the **Change Keyboard Macros** button brings up the **Function Keys** dialog. In this dialog you can select the desired function key and then enter your macro keystrokes in the associated key map. For example, to make **Ctrl-F2** the keystroke to send a trigger character, select **F2**, then in the **Ctrl** row, enter **<trigger character>** and click **OK**. Then whenever the **Ctrl-F2** keystroke is pressed, the trigger character will start the read cycle.

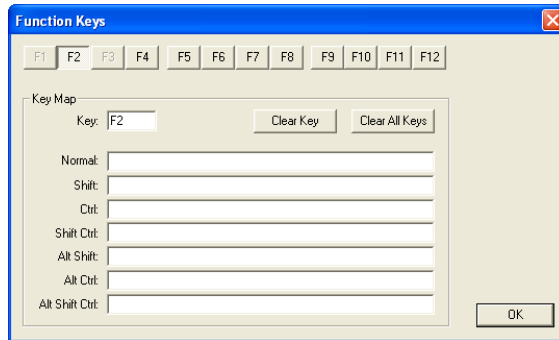

Note: The **F1** key is reserved for opening **ESP Help** and the **F3** key is reserved for the **Find Next** function.

Change Font

Sets the font characteristics for data received from the imager.

Change Echo Font

Sets the font characteristics of user-entered data.

Bar Code Options Tab

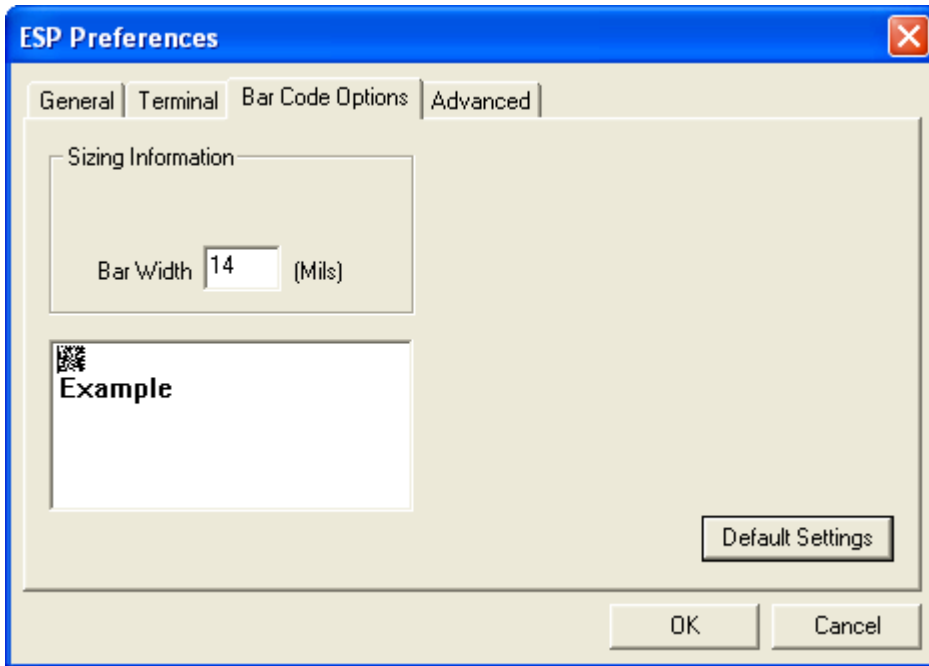

Sizing Information

Sets element size (in thousands of an inch) of symbols that you create and print from the **Bar Code Dialog** under **View**.

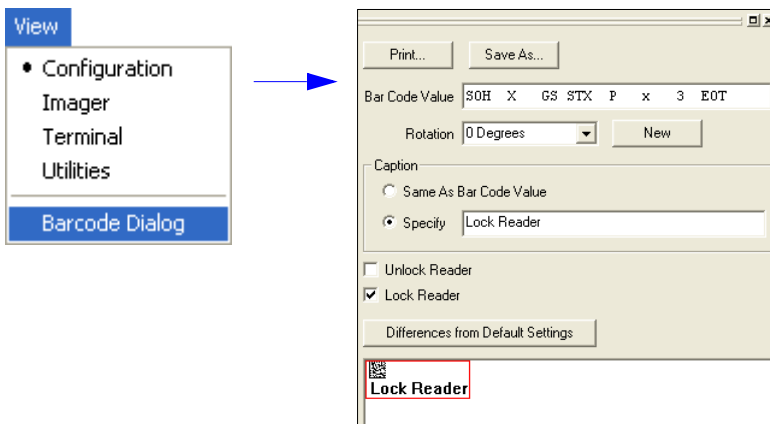

Advanced Tab

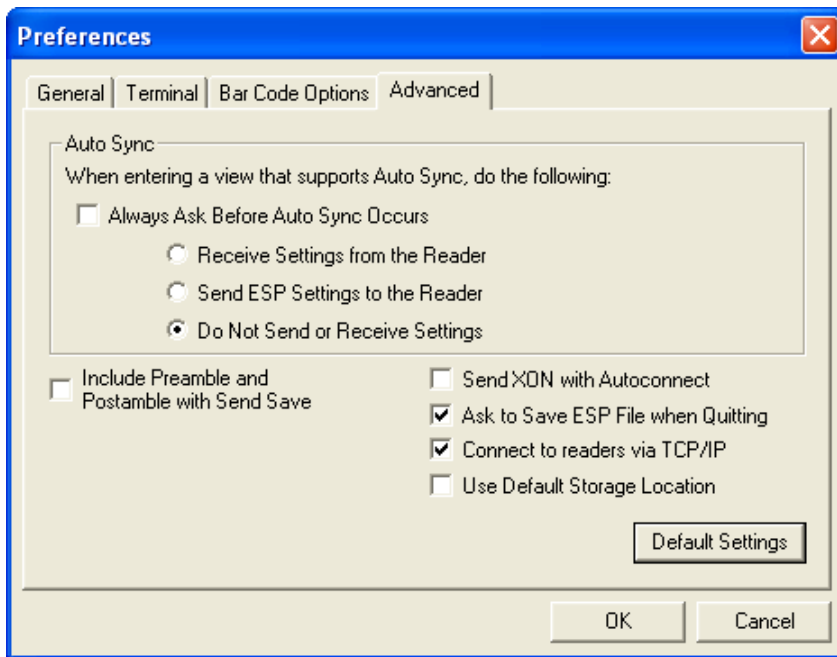

The Auto Sync dialog on the **Advanced** tab allows you to determine whether Auto Sync will be automatically enabled in sections of **ESP** where it is used, or if it will ask you before it enables Auto Sync functions.

Always Ask Before Auto Sync Occurs

If you check this option box, you are then able to determine what specific Auto Sync functions will be enabled. **Receive Settings from the Reader** will automatically send the imager's settings to **ESP** when Auto Sync is enabled. **Send ESP Settings to the Reader** will automatically send all imager configuration settings chosen in **ESP** to the imager. **Do Not Send or Receive Settings** creates a condition in which Auto Sync will not send imager settings to **ESP**, or send **ESP** settings to the imager.

Send XON with Auto-Connect

Sends an **XON (Begin Transmission)** command to the imager before starting the **Auto-Connect** routine.

Document Memo

The information you type in the **Document Memo** field will appear in a context-sensitive text box whenever your cursor hovers over the **Document Memo** item on the **Options** menu.

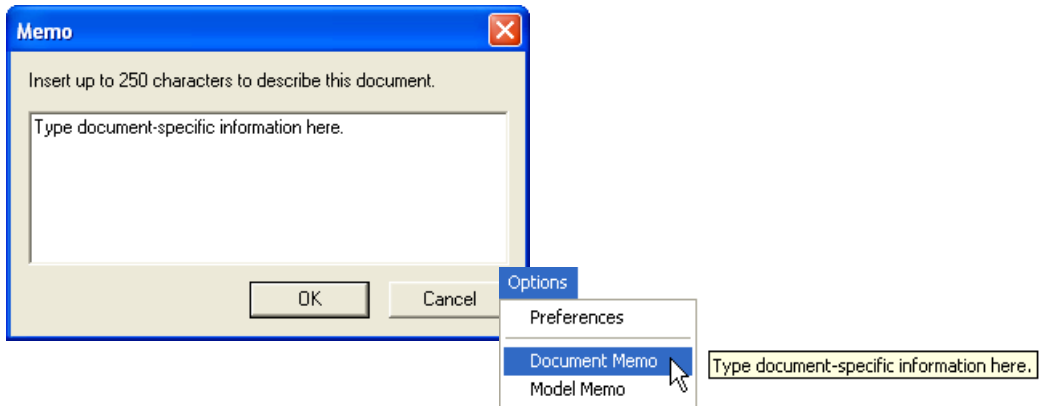

Model Memo

Similar to **Document Memo**, the information you type in the **Model Memo** field will appear in a context-sensitive text box whenever your cursor hovers over the **Model Memo** item on the **Options** menu. Memos created in **Model Memo** are specific to the model enabled when the message was created.

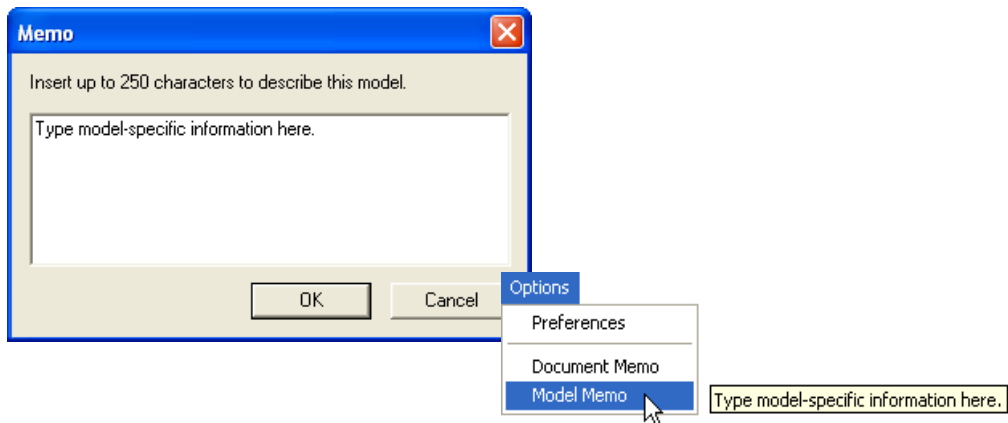

Note: Memos must be saved in a **.esp** file if you want them to be available in your next session. If you do not save your current session, any memos that you have entered during the session will be discarded, and will be unavailable in your next session.

Connect

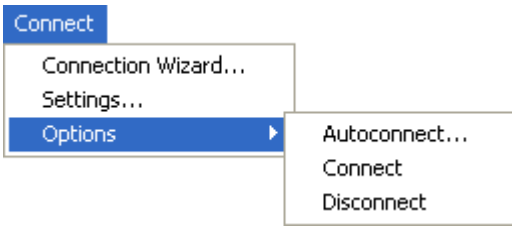

Connection Wizard

When you choose to connect to the imager via the **Connection Wizard**, you will first need to select the correct protocol (see [Select Protocol and Connect to Imager](#) in Chapter 1, [Quick Start](#).)

When you have successfully connected to the imager you will see one of the two following displays in the status bar at the lower right of the screen:

RS-232:

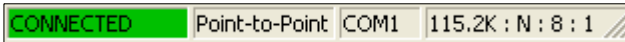

USB:

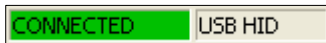

Settings / Options

Settings allows you to set baud rate, parity, stop bits, data bits and communications port for the RS-232 interface before connecting.

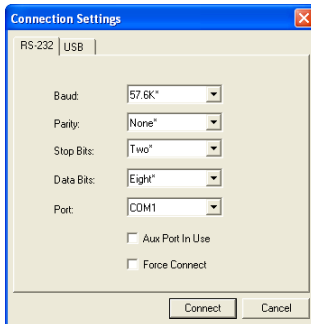

Options allows you to auto-connect to the imager (RS-232), follow standard connection procedure (RS-232 and USB), and disconnect the imager from **ESP** (RS-232 and USB).

View

The options in the **View** menu correspond to icons on the operations toolbar (**Configuration**, **Imager**, **Terminal**, **Utilities**). Each option allows you to configure the imager or to perform various other functions in the chosen view.

The **Imager**, **Terminal**, and **Utilities** views are explained fully in later sections.

The **View** menu also allows you to access the **Barcode Dialog**.



Barcode Dialog

In the **Barcode Dialog** you can directly type the text and commands you want to encode. This allows you to create configuration symbols that you can print and read with the imager.

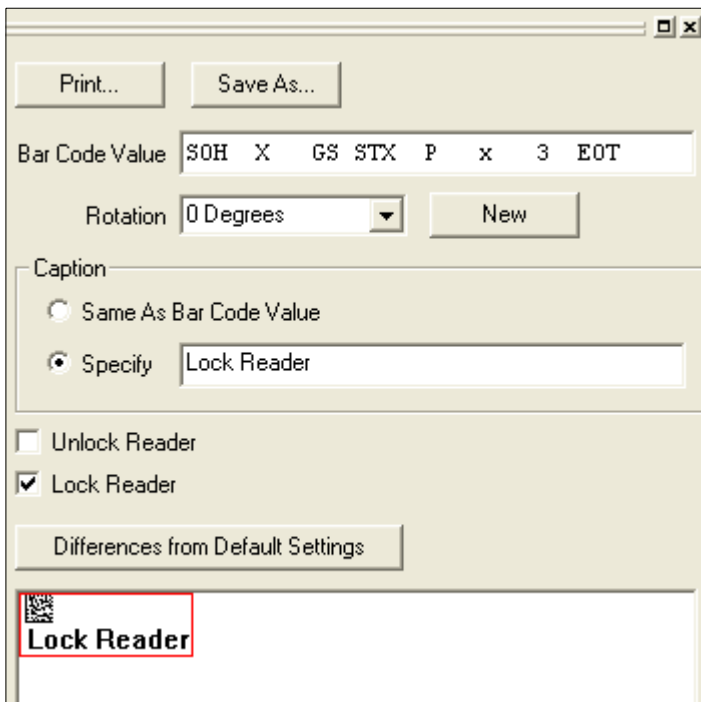

Send/Receive

To access **Receive**, **Save**, **Default**, and **Advanced** options, click the **Send/Recv** button.



You can also access these options by right-clicking in any of the configuration views.

Receive Reader Settings

From the **Send/Recv** menu, select **Receive Reader Settings**.

This option is useful if you want to receive the imager's settings and save them as a file for later retrieval. For example, if your imager has settings that you do not want to change, choosing **Receive Reader Settings** will allow you to load those settings to **ESP** and save them as an **ESP** file.

Receiving the imager's settings also assures that you will not subsequently save any unwanted configuration changes previously made in **ESP**.

Select this option if you want to upload the imager's settings to **ESP**. For example, if your **ESP** file has a number of custom settings that you want to maintain and download to the imager, you will lose those **ESP** settings if you choose to receive settings from the imager.

Save to Reader

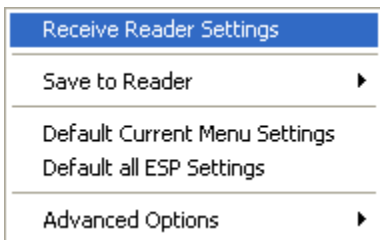

Send, No Save

This saves **ESP** settings to current memory.

Send and Save

This activates all changes in current memory *and* saves to the imager.

Default

When you select **Default Current Menu Settings** or **Default all ESP Settings** you are *only* defaulting settings in **ESP**. The imager is not affected unless you download new settings.

Advanced Options

Send Current View

This is the same as **Save to Reader > Send No Save** except that only the commands in the current menu tree are sent.

Send Current Command

This is the same as **Send Current View** above, but only saves the command that is currently selected.

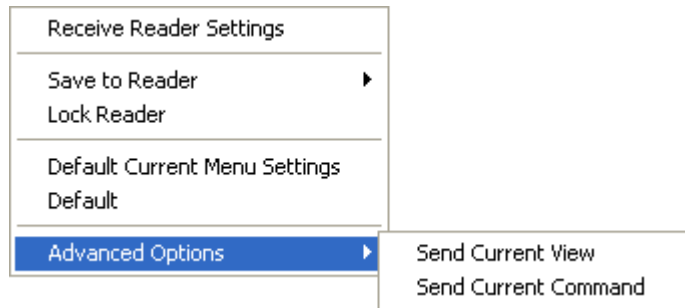

Send/Receive

3 Basic Operations

Contents

Step 1 Practice Targeting	3-2
Step 2 Determine Optimum Position	3-3
Step 3 Select Quadrus Only or Standard Mode	3-4
Step 4 Select Adaptive or Fixed Mode	3-5
Step 5 Complete Configuration	3-6
Trigger and Button Programming	3-7
USB Battery Charge Mode	3-8

This section explains how to practice targeting and triggering, how to begin configuring the imager, how to perform a hardware default, and how to switch between Quadrus Only and Standard modes. (Mode switching is available for MS-Q Quadrus models only.)

Step 1 — Practice Targeting



The laser beam can be harmful to eyesight. Avoid eye contact with the laser beam. Never point the beam at other people, or in a direction where people may be passing.

When first connecting, allow approximately 3 seconds for the imager to initialize.

1. Hold the imager steady and point at a symbol between **2.75** and **4.5** inches away (High Resolution Option) or between **2** inches and **19** inches away (Standard Resolution Option).
2. Squeeze and hold the trigger.
3. A red targeting spot will appear in front of the imager surrounded by a flashing **RED** LED pattern.
4. Center the laser spot on the symbol and wait a second or two for a decode.



For configuration symbols, you will hear **2 beeps** when a good read occurs. For data symbols, you will hear **1 beep** when a good read occurs.

5. If no decode occurs, slowly draw away from the symbol while holding the laser spot steadily in place.

Test Symbol



ABCDEFGHIJKLMNPO

Targeting Suggestions

- Typically, you should not hold the imager exactly perpendicular to the symbol. Position the imager about 15 to 30 degrees to avoid specular reflection.
- Do not wave the imager side-to-side or up-and-down, or attempt to sweep across a symbol; sudden movements will create fuzzy images and result in failed read attempts.
- The imager is omnidirectional and can read a symbol from any position (The exception to this is with certain linear symbols; in these cases, the read area will be oriented to the length of the symbol.)



Save Settings

M188_02



Default to USB

M049_03



Default to PS/2

M060_03



Clear All Data

M071_01



Clear XML Rules

M052_01

Step 2 — Determine Optimum Position

1. Position the reader in front of the symbol.
 - High Resolution Option: **2.75** inches for near field or **4.5** inches for far field.
 - Standard Resolution Option: **4** inches for near field and **9** inches for far field.
2. Determine the optimum read position by triggering at different distances and angles.
3. To speed up decoding, try enabling near field or far field only. (Both fields are enabled by default.)



In general, if the symbol element size is less than 0.010" (0.025 mm), enable near field to a focal point. If more than 0.010" (0.025 mm), try the far field focal point. Also, if symbols are placed closely together, you may want to use near field to lower the risk of reading the wrong symbol.

See [Trigger and Button Programming](#) on page 3-7 for the configuration symbols that correspond to these settings.

Other factors to consider:

- Use Both Fields for applications in which symbols may vary significantly in size and distance from reader.
- On Quadrus models, try **Fixed Mode** for even quicker decodes for symbols with consistent size and presentation (see [Select Adaptive or Fixed Mode](#) on page 3-5).
- For a more advanced setup, see [Trigger Optimization](#) on page 7-7.

Test Symbol



ABCDEFGHIJKLMNPO



M188_02

Save
Settings



M049_03

Default
to USB



M060_03

Default
to PS/2



M071_01

Clear
All Data



M052_01

Clear
XML
Rules

Select Quadrus Only or Standard Mode

Step 3 – Select Quadrus Only or Standard Mode

This feature is available for MS-Q Quadrus models only.

The firmware in the MS-Q Imager allows you to toggle easily between the specialized Quadrus Only Mode that is preferred for DPM (Direct Part Marking) or the more generalized Standard Mode.

As with the MS-Q Basic, in its default configuration, the MS-Q Quadrus's right button and handle also initiate reads; however, the left button is used to toggle between Quadrus Only and Standard Modes.

When you press the left button while in Quadrus Only Mode, you will hear 3 beeps and see the left indicator LED flash **RED** 3 times. This indicates the imager has switched to Standard Mode.

When you press the left button while in Standard Mode you will again hear 3 beeps, but now the left indicator LED flashes **GREEN** 3 times. This indicates the imager has returned to Quadrus Only Mode.

Note: Reprogramming the left button disables mode shifting.

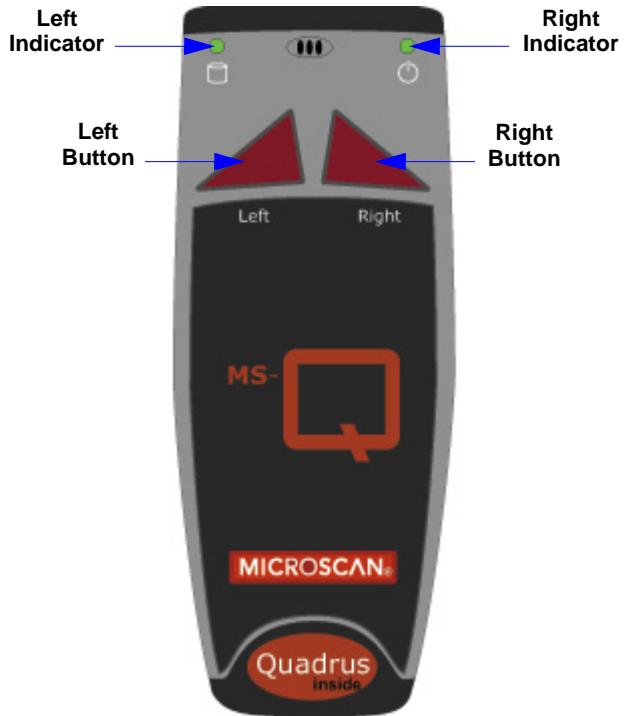

Test Symbol



ABCDEFGHIJKLMNOP



Save Settings

M188_02



Default to USB

M049_03



Default to PS/2

M060_03



Clear All Data

M071_01



Clear XML Rules

M052_01

Step 4 – Select Adaptive or Fixed Mode

This feature is available for MS-Q Quadrus models only.

When you read symbols in the MS-Q default setup, the imager is in **Adaptive Mode**. In this mode, when the imager is activated by the handle trigger, it attempts to decode in both the near field and far field resolutions, checks for both light background or dark background images, and cycles through various gain values until a decode is achieved. It remains with those settings unless no decode occurs within ten attempts, in which case it resumes the adaptive routine.

If your application involves relatively similar symbols at consistent ranges, you might speed up decode rates by switching the imager from **Adaptive Mode** to **Fixed Mode**. When you switch to **Fixed**, the optimum settings acquired in **Adaptive** will be locked in. This means that the imager will not have to search through the various settings to arrive at the optimum. However, the settings will be fixed to the distance, symbol background, etc. that were in effect when the last decode occurred in the **Adaptive Mode**.

Toggle Between Adaptive and Fixed

To toggle between the **Adaptive** and **Fixed** Modes:

1. Find a position that gives you the best decodes. (See [Determine Optimum Position](#) on page 3-3.)
2. Press both the **left** and **right** top buttons at the same time and hold until you see both LED indicators (on top) flash **RED** twice. This indicates that the imager is now in Fixed Mode.
3. To return to Adaptive Mode, press both buttons again until the indicators flash **GREEN** twice, indicating that you have returned to Adaptive Mode.

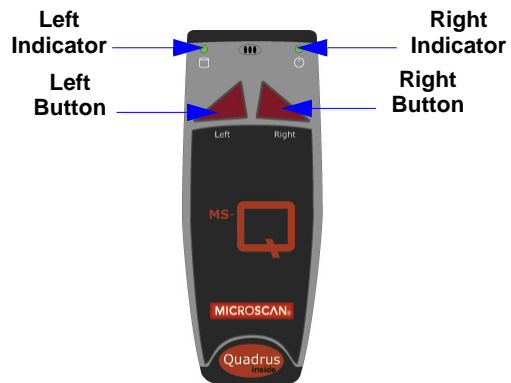

MS-Q settings can also be **locked** and **unlocked** by reading the following symbols:



M429_01

MS-Q Settings Locked



M428_01

MS-Q Settings Unlocked



Test Symbol
ABCDEFGHIJKLMNPO



M188_02

Save Settings



M049_03

Default to USB



M060_03

Default to PS/2



M071_01

Clear All Data



M052_01

Clear XML Rules

Step 5 — Complete Configuration

For the MS-Q Basic, in the default configuration, both the **left** and **right** buttons as well as the handle trigger can initiate reads.

For the MS-Q Quadrus, in the default configuration, the **right** button and handle trigger also initiate reads; however, the **left** button is used to toggle between Quadrus Only and Standard Modes.

Test Symbol



ABCDEFGHIJKLMNOP

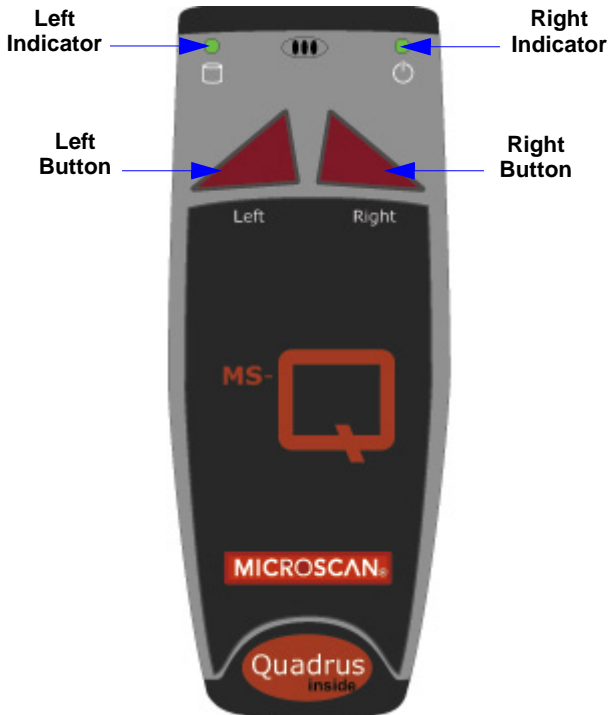

Save Settings

M188_02



Default to USB

M049_03



Default to PS/2

M060_03



Clear All Data

M071_01



Clear XML Rules

M052_01

Trigger and Button Programming

Trigger and button functionality can be configured to read just near field, just far field, or both fields using the symbols listed below. See also [Trigger Optimization](#) on page 7-7.

Handle Trigger

Both Fields (Default)



M157_03

Near Field Only



M156_03

Far Field Only



M155_03

Left Button

Both Fields (Default)



M178_01

Near Field Only



M177_01

Far Field Only



M176_01

Right Button

Both Fields (Default)



M185_01

Near Field Only



M184_01

Far Field Only



M183_01

Continuous Read

Both Fields



M138_02

Near Field Only



M140_02

Far Field Only



M139_02

Continuous Read Disabled (Default)



M141_03



M188_02

Save Settings



M049_03

Default to USB



M060_03

Default to PS/2



M071_01

Clear All Data



M052_01

Clear XML Rules

USB Battery Charge Mode

If you choose to charge the MS-Q Imager's battery with a USB connection, you have the option of using **USB Battery Charge Mode**. This mode dedicates most of the power available from the USB connection to charging the battery. Read the symbol below to enable this mode.



Enable USB Battery Charge Mode



Default to Previous Settings (Disable USB Battery Charge Mode)

Note: The imager is able to read and decode symbol data while in USB Battery Charge Mode. After each symbol decode the imager automatically returns to its battery charging state.



Save Settings

M188_02



Default to USB

M049_03



Default to PS/2

M060_03



Clear All Data

M071_01



Clear XML Rules

M052_01

4 Communications

Contents

Communications by ESP	4-2
Communications Overview	4-3
USB Interface	4-4
PS/2 Interface	4-5
RS-232 Interface	4-6
Bluetooth Interface	4-8
Batch/Battery	4-16
Preamble	4-20
Postamble	4-21
Preamble and Postamble by ESP	4-22
Keyboard Mapping	4-23
Text Commands	4-24
Time Stamp	4-25
Other Communications Settings in ESP	4-26

This section includes connection parameters and options for communicating with the MS-Q Imager in various interfaces.

Communications by ESP

To make changes to configuration settings in the **Communications** tree control:

Parameters	
[-] Communications	
+ Communications Mode	USB Keyboard
USB Keyboard Rate	10
[-] RS232	
Batch Mode	Detect RS232
Baud Rate	57.6K
Parity	None
Stop Bits	Two
Data Bits	Eight
Keyboard Mapping	US English (with leading 0 in alt-num)
Reader Auto Connect	Enabled
Reconnect Timeout	90
Reader Auto Disconnect	Disabled
Max Connection Wait Time	30
Bluetooth Out of Range Alarm	Disabled*

1. **Left click** on the + to expand the tree.

2. **Double click** on the parameter and click once in the selection box to view options.

3. Place your cursor in the selection box, scroll down to the setting you want to change and **click once** on the setting.

4. **Left click** again on the open screen to complete the selection.

5. **Right click** on the open screen and select **Save to Reader** to implement the command in the imager.

Communications Overview

All MS-Q Imagers are shipped with a USB or PS/2 cable. You can also add RS-232 and Bluetooth capabilities and configure your imager accordingly. Whenever you default the imager, it will return to the default settings of whichever interface you are using. Defaulting the imager does not remove preamble and postamble formatting.

Note: You must use **USB Connect Mode** or **RS-232 Connect Mode** to connect to **ESP**. Once the imager is connected to **ESP**, you can select your communications mode and set other communication parameters.

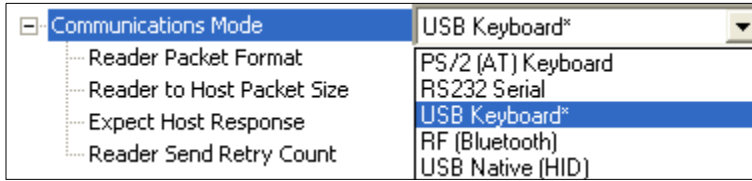

USB

With USB communications, the imager connects directly to the host's USB port from which it draws its power. Data is displayed by any open Windows-based program that can capture text in USB Keyboard Mode.

PS/2

With PS/2 communications, the imager connects directly to the host's keyboard port from which it draws its power. Data is displayed by any open Windows-based program that can capture text in PS/2 Keyboard Mode.

RS-232

With RS-232 communications the imager communicates with the host through a communications program such as HyperTerminal.

Default settings for establishing RS-232 communications are:

Baud =	57.6K
Parity =	None
Stop Bits =	Two
Data Bits =	Eight
Flow Control =	None

Bluetooth

The Bluetooth version of the imager includes an internal Bluetooth wireless radio. The radio allows for point-to-point wireless communication with other Bluetooth devices that support serial port protocol (SPP).

Batch/Battery

The MS-Q's **Batch Mode** is intended for applications that require a portable reader. Scanned data is saved to the imager's non-volatile memory, and can then be transferred to a host.

USB Interface

USB Keyboard is the default interface in which data is transferred to a Windows-based text program as keyboard data.

See **USB Interface** on page 1-6 for detailed steps on setting up the USB Interface.

USB Keyboard Mode

Data is entered as keyboard sequences. You need to read this symbol whenever you are changing from a different interface to USB.



M134_02

USB Downloader Mode

This mode is the standard way of transferring unformatted, unpackitized data to the imager through the USB port.



M133_01

USB Native Two-Way Mode

This mode is used when the user needs error-corrected communication between the MS-Q and the host the USB port.



M135_04

USB Virtual COM Mode

This mode allows an MS-Q in a USB configuration to function as a virtual serial COM port. This mode requires installation of a USB Virtual COM driver. Contact your Microscan sales representative to request this driver, as well as installation instructions.



M668_01



Save Settings

M188_02



Default to USB

M049_03



Default to PS/2

M060_03



Clear All Data

M071_01



Clear XML Rules

M052_01

PS/2 Interface

PS/2 Keyboard is the default interface in which data is transferred to a Windows-based text program as keyboard data.

See [PS/2 Interface](#) on page 1-7 for detailed steps on setting up the PS/2 interface.

PS/2 Keyboard Mode

Data is entered as keyboard sequences. Read this symbol whenever you are changing from a different interface to PS/2.

Important: The imager *must* be connected to the keyboard for the imager and the keyboard to function in PS/2 Keyboard Mode.



M126_01



M188_02

Save
Settings



M049_03

Default
to USB



M060_03

Default
to PS/2



M071_01

Clear
All Data



M052_01

Clear
XML
Rules

RS-232 Interface

Enabling either of these modes will disable USB or PS/2 communications and require you to default the imager or read the “USB Keyboard” symbol to return to USB.

See [RS-232 Interface](#) on page 1-8 for detailed steps on setting up the RS-232 Interface.

RS-232 Default Settings Mode

This mode is the standard way of transferring unformatted, unpacketized data through the RS-232 port.



MS101_01

You will need to read this symbol whenever you set up RS-232 communications.

Baud Rate (RS-232)

Baud Rate is the rate at which the imager and host transfer data. It only needs to be changed if necessary to match the host setting.



1200

M092_01



19.2K

M096_01



2400

M093_01



38.4K

M097_01



4800

M094_01



57.6K (Default)

M098_01



9600

M095_01



115.2K

M099_01



Save Settings

M188_02



Save Settings

M188_02



Default to USB

M049_03



Default to PS/2

M060_03



Clear All Data

M071_01



Clear XML Rules

M052_01

Parity (RS-232)

Parity is an error detection routine in which one data bit in each character is set to **1** or **0** so that the total number of 1 bits in the data field is even or odd. It only needs to be changed if necessary to match the host setting.



None (Default)

M103_01



Odd

M104_01



Even

M102_01

Stop Bits (RS-232)

Stop Bits are added to indicate the end of each character. This setting should only be changed if necessary to match the host setting.



2 Stop Bits (Default)

M106_01



1 Stop Bit

M105_01

Data Bits (RS-232)

Data Bits are the total number of bits in each character. This setting only needs to be changed if necessary to match the host setting.



8 Data Bits (Default)

M101_01



7 Data Bits

M100_01

Timeout Settings (Cabled)

This feature sets the amount of time a cabled MS-Q will be enumerated before entering **Sleep Mode** in order to charge the battery more quickly.



**Cabled Timeout -
Never (Default)**

M137_01



**Cabled Timeout -
2 Hours (Default)**

M136_01



Save
Settings

M188_02



Default
to USB

M049_03



Default
to PS/2

M060_03



Clear
All Data

M071_01



Clear
XML
Rules

M052_01

Bluetooth Interface

USB

For quick setup information about connecting to the Bluetooth modem via USB, see [Bluetooth Interface](#) on page 1-9.

RS-232

Once the imager is connected via RS-232, the software on the host must be open to receive data with a communications program such as HyperTerminal.

Baud =	57.6K
Parity =	None
Stop Bits =	One
Data Bits =	Eight
Flow Control =	None

The Bluetooth radio is a Class 1 device. If connected to another Class 1 device the imager has roughly 100 meters (328 feet) line-of-sight operating range. If connected to a Class 2 or Class 3 device, the operating range may drop to match the lower range.

When the imager detects that the radio is out of range, it will store data in non-volatile memory. The imager will continue to try to send data until the radio is back in range. Once the data is sent, it will be erased from the unit's memory unless **Batch Mode** is set for **Send and Log**. If the radio cannot connect in 90 seconds, it will emit an error beep. The imager will continue to try to connect until it has reached the programmable radio timeout setting.

If the imager is in **RF Two-Way Mode** and **Auto-Connect** is enabled (which it is by default), it will automatically attempt to reconnect with the host modem whenever:

- The imager is powered-on.
- The imager attempts to read another symbol.

Another important thing to consider is Bluetooth access. You choose **Private** when you want to limit access to only one imager. You choose **Shared** when you want more than one imager to have continuous access.

Connecting to the Bluetooth Modem via RS-232

RF Two-Way is the mode used when communicating with the Bluetooth modem in RS-232. It is used when there is a need for bidirectional communication between the imager and an application by radio frequency (i.e. Time Stamp, Error Checking, Shared Access, etc.). The imager receives confirmation via packet protocol verification and is 100% reliable.

To connect to the Bluetooth modem:



1. Read the **RF Two-Way Mode** symbol at right.
2. Read the Quick Connect Symbol located on the **TOP** of your connected Bluetooth modem to establish communications.
3. Read the **Save Settings** symbol.



M129_02

**RF Two-Way
Mode**

Bluetooth Communication Indicators

Bluetooth Activity	 Memory LED (LEFT indicator)	 Battery LED^a (RIGHT indicator)	Sound
<i>Attempting to Connect to Bluetooth</i>	Flashes BLUE	Solid GREEN	None
<i>Bluetooth Connection Failed</i>	None	None	4 beeps
<i>Bluetooth Connection Successful</i>	Flashes BLUE every 15 seconds	Flashes Battery Status every 15 seconds	None
<i>Sending Bluetooth Data</i>	Flashes Memory Status	None	None

a. When power is supplied via cable, the LED will remain green whenever the imager is active.

Disconnect

You may force disconnection by reading the **Disconnect** symbol (in a Primary/Secondary Bluetooth connection, the imager may not appear disconnected for 10 to 15 seconds after the command is sent). The imager will also disconnect (go into **Sleep Mode**) after a period of inactivity (see **Sleep Mode Timeout** on page 4-12).



M114_02

Disconnect

Auto-Connect

After coming out of Sleep Mode or after powering-on, the imager tries to auto-connect with the last host modem it had been connected with.

If **Auto-Connect** is enabled, the imager will connect to the host whenever it has data and the imager is idle (but not asleep).

Auto-Connect (Default)



M068_01

This allows connected imagers to send data whenever it is read.

Disable Auto-Connect



M067_01

An imager that reads this symbol will not connect to the modem until re-programmed to do so.

Important: One-Way Mode is not supported by the Microscan Bluetooth modem. **One-Way Mode** is supported by most other Bluetooth modems (Belkin, for example).

One-Way Mode Options

One-Way Mode is only recommended when connecting to a device well within the imager's specified range, or when connecting to a device without an operating system (a printer, for example).

RF One-Way Mode (Maximum Range)



M127_01

This mode is the standard way of transferring unformatted, unpacketized data by radio frequency. The **Maximum Range** setting optimizes the imager for greater range but data reliability is lower.

RF One-Way Mode (Maximum Reliability)



M128_01

The **Maximum Reliability** setting optimizes the imager for greater reliability but the radio range is lower.

Always read the **Save Settings** symbol after changing connectivity options.



M684_01

Default RF



Save Settings

M188_02



Default to USB

M049_03



Default to PS/2

M060_03



Clear All Data

M071_01



Clear XML Rules

M052_01

Bluetooth Access

When the default **Private Access** is enabled, only one active and connected imager will be able to send data. An imager remains active if it is connected and has not reached the timeout period set in **Sleep Mode Timeout**. If it enters **Sleep Mode**, any other imager enabled for **Private Access** can become active and maintain exclusive access as long as it remains active itself.

When **Shared Access** is enabled, an imager will disconnect from the host after a successful data transmission and re-connect only when it has new data to send and the host port is available. In this mode any imager can send data, but since an imager must identify itself each time it connects, a few seconds of latency will necessarily occur before each transmission. This does not prevent the imager from reading and decoding while awaiting access.

All imagers must have **Shared Access** enabled before this mode can function in any of the imagers individually. **Auto-Connect** should also be enabled (otherwise, it will be necessary to read a **Quick Connect Code** before every re-connect and data transmission).



M065_01

Private Access (Default)



M066_01

Shared Access

Important: **Shared Access** is recommended only when **RF Two-Way Mode** is enabled.



M684_01

Default RF

Bluetooth Access by ESP

In **ESP**, Bluetooth Access settings are controlled by the **Reader Auto-Disconnect** command in the **Communications** tree control.

When Auto-Disconnect is **Disabled**, the MS-Q retains a connection to the host until it enters **Sleep Mode** or until an explicit Disconnect command is sent (**Private Access**).

When Auto-Disconnect is **Enabled**, the MS-Q will disconnect whenever there is no data to send to the host. When there is data to send, the MS-Q will connect, send the data, and disconnect once again (**Shared Access**).

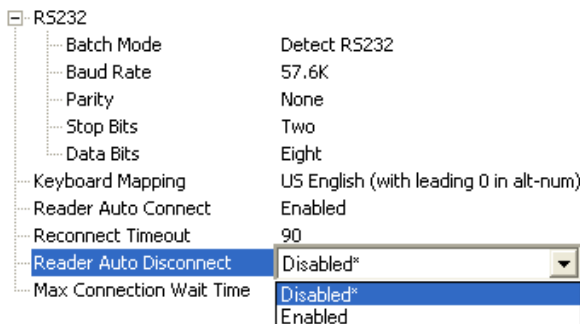

Sleep Mode Timeout

Following a period of inactivity, the imager will go into **Sleep Mode**, during which it will no longer signal its presence to the modem. It leaves Sleep Mode whenever it is powered-on or a read is attempted.

When the imager leaves Sleep Mode, there will be approximately 5 seconds of connect time before a symbol can be read and transmitted.

Read the symbols below to set the period of time before Bluetooth enters Sleep Mode.



90 Seconds (Default)

M125_01



30 Minutes

M124_01



5 Minutes

M121_01



1 Hour

M119_01



10 Minutes

M122_01



2 Hours

M120_01



15 Minutes

M123_01

Note: Increasing the amount of time before the imager times out will decrease battery life.

Note: If the imager has power (USB cable, power cable, etc.) it will disconnect based on Cabled Timeout settings.



Default RF

M684_01



Save Settings

M188_02



Default to USB

M049_03



Default to PS/2

M060_03



Clear All Data

M071_01



Clear XML Rules

M052_01

Out-of-Range Notification

This feature allows you to set the imager to beep or vibrate when the Bluetooth radio is out of range. Read the symbols below to set the desired **Out-of-Range Notification** profile.



M583_01

Enable Out-of-Range Beep



M582_01

Enable Out-of-Range Vibrate



M587_01

Enable Out-of-Range Beep and Vibrate



M581_01

Disable Out-of-Range Notification (Default)



M684_01

Default RF

Auto-Save Last Bluetooth Address

If the MS-Q is saved in the proper RF communication mode, enabling **Auto-Save** will allow the imager to automatically save the last device to which it was connected. This eliminates the need to **Save Settings** after reading the Quick Connect Code.



M747_01

Disable Auto-Save (Default)



M746_01

Enable Auto-Save



M684_01

Default RF



M188_02

Save Settings



M049_03

Default to USB



M060_03

Default to PS/2



M071_01

Clear All Data



M052_01

Clear XML Rules

Lockout Link Mode

Lockout Link Mode can be used to establish a permanent connection between the MS-Q and a Bluetooth Modem.

- Read the **Quick Connect Code** on the top of the modem to which you wish to establish a permanent link.
- Listen for the single beep to indicate a successful connection.
- Read the **Lockout Link Mode** symbol below.

To reassign a permanent connection between the modem and a different MS-Q, read the **Unlock Link** symbol below. Follow the above instructions with the new imager to establish the new connection.



M710_02

Lockout Link Mode



M711_01

Unlock Link



Save Settings

M188_02



Default to USB

M049_03



Default to PS/2

M060_03



Clear All Data

M071_01



Clear XML Rules

M052_01

Connecting via RS-232 with a USB Bluetooth Modem

In some applications, it may become necessary to connect to a host via RS-232 using a USB Bluetooth Modem. The following steps allow you to convert a USB Bluetooth connection to RS-232.

1. Plug the USB cable into the Bluetooth Modem and the host computer's USB port.

Important: You must use a charged MS-Q battery for this procedure to work properly.

2. Read the **Quick Connect Code** on the top label of the Bluetooth Modem.

You will now be able to decode and send data to a program in the host computer that can receive and display data.

3. Read the **RS-232 Bluetooth Mode** symbol and then the **Save Settings** symbol at the bottom of this page.

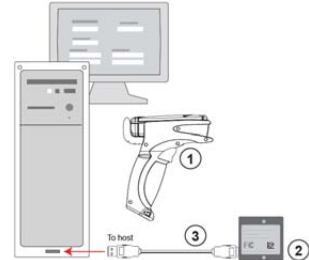

RS-232 Bluetooth Mode

M661_01

4. Plug the Bluetooth Modem into an RS-232 connector and power supply.
5. Open a terminal program and connect using the following port settings:

Baud = **9600**
 Parity = **Even**
 Stop Bits = **One**
 Data Bits = **Seven**
 Flow Control = **None**

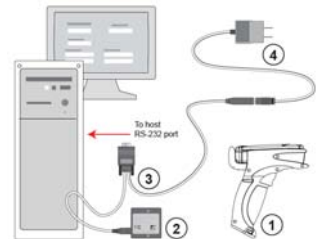

6. Read the symbol below to return to **USB Bluetooth Mode**, and then read the **Save Settings** symbol at the bottom of this page.



USB Bluetooth Mode

M708_01



Save Settings

M188_02



Default to USB

M049_03



Default to PS/2

M060_03



Clear All Data

M071_01



Clear XML Rules

M052_01

Batch/Battery

See **Batch/Battery Interface** on page 1-10 for instructions on installing the battery.

The battery automatically charges every time a cable interface is attached to the imager and the host is powered-on.

The RS-232 interface power adapter must be plugged into a wall socket for the battery to charge.

In USB and PS/2 interfaces, the imager and battery draw their current from the host computer.



Typical Battery Charge Times

USB and PS/2	RS-232	Battery Charger
6 to 8 hours	6 to 8 hours	4 hours

Typical Battery Usage when not connected to the host:

- Up to 8 hours Standby
- Up to 4,000 reads

Batch/Battery Communication Indicators

Imager Activity	 Memory LED (LEFT indicator)	 Battery LED ^a (RIGHT indicator)	Sound
<i>Successful Decode and Data Storage</i>	Memory Status	None	1 beep
<i>Batch Memory Full</i>	Solid RED	None	3 beeps

a. When power is supplied via cable, the LED will remain green whenever the imager is active.

Important: When the memory LED turns **RED**, you *must* download or data will be lost.

Batch Mode Options

The MS-Q Imager features three different Batch Modes for applications requiring a portable imager. Batch Modes allow a user to save data to the imager's non-volatile memory and later transfer that data to a host computer when connected, either by USB or RS-232 cable, or by Bluetooth.

The imager's dedicated batch memory is a minimum of 1MB.

The imager will automatically detect when the Bluetooth radio is out of range, or a USB or RS-232 cable is detached (provided it is plugged into a power supply). If a battery is installed, the imager will switch to Batch Mode and buffer the data in non-volatile memory.

Send and Buffer Mode (Default)



M075_01

If you read the **Send and Buffer Mode** symbol at left, all data in the buffer will be downloaded to the host and **ERASED** in the imager whenever you connect.

You must have a data collection program open before connecting in this mode *or all buffered data will be lost*.

Important: Once the unit is reattached to a cable or enters within radio range, decoded data will NOT be saved to non-volatile memory. If you are using an RS-232 connection, the imager must be in Batch Mode for the data to be stored.

Log Only Mode



M072_01

In **Log Only Mode**, the imager will only store data in non-volatile memory. You can only send the data by sending the **Transfer All Data** command. Once the memory has been transferred to a host, all of the data will still reside in memory.

You must read the **Delete Data** symbol to clear memory.

Send and Log Mode



M076_01

If you read the **Send and Log Mode** symbol to the left, all data in the buffer will be downloaded to the host but retained in the imager's memory whenever you connect. The data can be transferred again by reading the **Transfer All Data** symbol.

Reconnecting to the Host

When reconnected to the host, or when the Bluetooth Radio is back in range, the imager will automatically detect the connection and, depending on the Batch Mode, transfer or log (retain) buffered data. The imager can be considered connected if:

- The **Bluetooth radio** is in range and active.
- The **USB cable** is attached to a host computer and the imager is enumerated.
- It is in **RS-232 Mode** and the cable is attached to a host with power supply plugged in.
- The **RS-232 cable** is attached to a host computer with power supply and the imager is in **Batch Mode**.



M188_02

Save Settings



M049_03

Default to USB



M060_03

Default to PS/2



M071_01

Clear All Data



M052_01

Clear XML Rules

Transferring and Deleting Data

The MS-Q Imager has three different commands that can transfer data or delete data in memory.

Transfer All Data



M077_02

All data in memory is sent every time the **Transfer All Data** symbol is read.

Transfer New Data



M078_02

Every time the **Transfer New Data** symbol is read, only the data in memory that hasn't been sent will be transferred.

Note: This command is not applicable in **Log Only Mode**. If you are in **Log Only Mode**, use **Transfer All Data**.

Delete Data



M071_01

Reading the **Delete Data** symbol will erase all data in the imager's non-volatile memory.

Auto-Transfer Buffer Memory

By default, when the MS-Q re-connects to the host, it will automatically transfer any data in memory. If the application on your host computer is not ready, the imager will send the data anyway, and the data could be lost. If you do not wish for the imager to send data immediately upon connection, read the **Disable Auto-Transfer Buffer Memory** symbol.



M070_01

Enable Auto-Transfer Buffer Memory (Default)



M069_01

Disable Auto-Transfer Buffer Memory



M188_02

Save Settings



M049_03

Default to USB



M060_03

Default to PS/2



M071_01

Clear All Data



M052_01

Clear XML Rules

RS-232 Batch Features

RS-232 interfaces will NOT detect when an RS-232 cable is removed unless the power supply for that cable is plugged in. If your power cable is unplugged, you still enter **Batch Mode** by reading the **RS-232 Batch (Cable Detect)** symbol below.

However, when you re-connect to the RS-232 power supply you must enable **RS-232 Cabled - No Power** to put the imager back in **Cabled** mode. In **RS-232 Cabled**, the imager has no way to check if it is unplugged. Therefore, collected data will be automatically sent out the disconnected port (i.e., it will not buffer the data—it will only log it, assuming the imager is in **Send and Log Mode**.) This data would be lost if the imager were in **Send and Buffer Mode**.



**RS-232 Batch
(Cable Detect)**

M073_02



RS-232 Cabled - No Power

M074_02

The opposite is true for **RS-232 Batch (Cable Detect)**. In this mode, the imager assumes that it is NOT cabled. It will buffer and log the data unless you plug it into the cable that has a power supply. The imager will be able to detect the power source and will automatically switch to cabled operation.

Important: When the imager is in **RS-232 Cabled Mode**, it will behave as if it is being attached to a cable when it is placed in the battery charger. This will cause it to download collected data, and *the data will be erased from memory*. To disable this feature, read the **RS-232 Batch (Cable Detect)** symbol.



Save
Settings

M188_02



Default
to USB

M049_03



Default
to PS/2

M060_03



Clear
All Data

M071_01



Clear
XML
Rules

M052_01

Preamble

A **preamble** is a character or series of characters that is added to the beginning of a decoded data string. Preamble characters will appear in the order that they are enabled (left to right). For example, if you enable a comma and then a space, and then decode a symbol containing the data 'ABC', your output will look like this:

, ABC

The only limit to the number of preambles enabled is the total memory size available.

Important: Be sure to save all settings before reading any of the following preamble symbols—otherwise your settings may be lost.



Save Settings

M188_02

Set the desired preamble by reading the appropriate symbol below.



M159_02

Comma



M164_02

Space



M166_01

Tab (USB Only)



M218_02

Tab



M404_01

**Erase All
Preamble Data**



M214_02

**Carriage Return
Line Feed**

Important: Use only with serial applications.

Note: To erase all preamble *and* postamble data, read the following symbol:



M406_02

Erase Preamble and Postamble Data

Postamble

A **postamble** is a character or series of characters that is added to the end of a decoded data string. Postamble characters will appear in the order that they are enabled (left to right). For example, if you enable a space and then a comma, and then decode a symbol containing the data 'ABC', your output will look like this:

ABC ,

The only limit to the number of postambles enabled is the total memory size available.

Important: Be sure to save all settings before reading any of the following postamble symbols—otherwise your settings may be lost.



M188_02

Save Settings

Set the desired postamble by reading the appropriate symbol below.



M168_04

Important: Use only with serial applications.

Carriage Return



M160_04

Comma



M169_04

Line Feed

Important: Use only with serial applications.



M170_04

Important: Use only with serial applications.

**Carriage Return
Line Feed**



M165_04

Space



M161_04

Enter

Important: Use only with USB or PS/2 Keyboard modes.



M167_04

Important: Use only with USB or PS/2 Keyboard modes.

Tab



M219_04

Tab (RS-232 Only)



M405_02

Erase / None

Important: Reading this symbol will erase all postamble data.

Note: To erase all postamble and preamble data, read the symbol at right:



M406_02

**Erase Preamble
and Postamble
Data**

Preamble and Postamble by ESP

Characters can also be added to the beginning and end of data strings using **ESP**. There are a few different ways to do this, using the interface shown below.

You will see the Communications tree control on the left, and the Preamble/Postamble interface on the right.

When you type ASCII characters directly into the **Preamble** or **Postamble** text fields and then click **Send to Reader**, those preamble or postamble characters are enabled and will appear in data output.

The screenshot shows the top portion of the Preamble/Postamble interface. It features two text input fields: 'Preamble:' containing a single space character and 'Postamble:' containing '/n'. To the right of these fields are two buttons: 'Save As...' and 'Send to Reader'. Below the text fields are two radio buttons: 'Preamble' (unselected) and 'Postamble' (selected). A callout box with a blue border and arrow points to the 'Send to Reader' button, containing the text: 'Save pre- and postamble settings and send them to the reader.'

The screenshot shows the middle portion of the interface. It features a dropdown menu with the text '/n - Enter key' and a button labeled 'Insert'. Below the dropdown menu is a grid of preset buttons: Alt, Ctrl, Shift, Windows, Home, End, Enter, Escape, Page Up, Backspace, Page Down, Up, Left, Down, and Right. A callout box with a blue border and arrow points to the 'Insert' button, containing the text: 'Scroll through a list of all preamble and postamble options, and then click **Insert**.'

In addition to typing directly in the text fields and selecting from the dropdown menu, you can also click any of these preset buttons to set a preamble or postamble.

The screenshot shows the bottom portion of the interface, displaying a grid of preset buttons. The buttons are arranged in four rows: Row 1: Carriage Return (CR), % - Percent Sign Esc, 500 ms Delay; Row 2: Tab - Keystroke/USB, Tab - Ascii, / - Forward Slash Esc; Row 3: Left, Down, Right; Row 4: (empty). A callout box with a blue border and arrow points to the 'Backspace' button, containing the text: 'In addition to typing directly in the text fields and selecting from the dropdown menu, you can also click any of these preset buttons to set a preamble or postamble.'

Keyboard Mapping

The **Keyboard Mapping** feature provides alternatives for keyboards that do not conform to US English mapping.

Note: Universal Keyboard mapping is slightly slower than the other language-specific options, because it maps data by reference to the full set of ASCII characters. The advantage of Universal Keyboard mapping is that it allows any language and keyboard layout to be mapped.

Important: Keyboard Mapping is not to be confused with USB Keyboard Mode, which has an entirely different function—namely to enable USB cabled communications. (See [USB Interface](#) on page 1-6).



M172_01

US English, No Leading 0 (Default)



M602_01

US English, Leading 0



M606_01

US English, Ctrl + Char, for Non-Printable ASCII



M603_01

French



M604_01

German



M605_01

Japanese



M173_01

Universal Keyboard



M171_01

Custom Keyboard

Keyboard Mapping by ESP

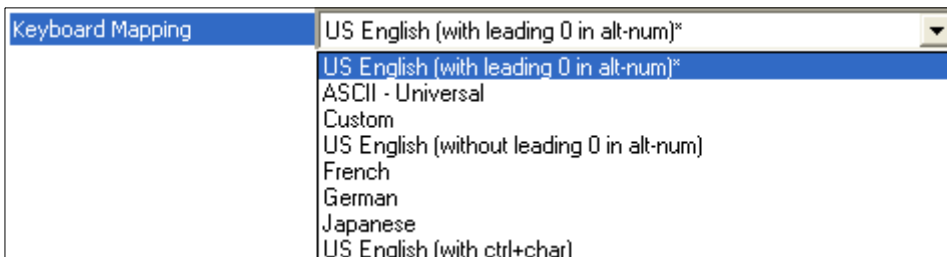

M188_02

Save Settings



M049_03

Default to USB



M060_03

Default to PS/2



M071_01

Clear All Data



M052_01

Clear XML Rules

Text Commands

When the **Text Commands** feature is enabled, the MS-Q can accept text commands via RS-232 or RF connections.



Enable Text Commands (Default)



Disable Text Commands

Text Commands by ESP

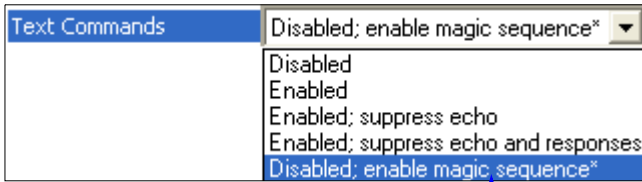

When **Magic Sequence** is enabled, it allows the user to enable **Text Commands** by entering a predetermined series of keystrokes.

When **Text Commands** are set to **Enabled; Suppress Echo**, text that a user enters in the terminal will not be shown. When **Text Commands** are set to **Enabled; Suppress Echo and Responses**, neither user-entered data or reader responses will be shown, and only decoded symbol data will appear in the terminal. See [Terminal Right-Click Menu](#) on page 8-6 for a way to change Echo settings directly in the terminal view.

Entering Magic Sequence

The magic sequence is `>PA` followed by a numeric value of **1**, **3**, or **7**.

- 1** = Enable Text Commands
- 3** = Enabled; Suppress Echo
- 7** = Enabled; Suppress Echo and Responses

In the example below, the magic sequence entered will Enable Text Commands and Suppress Echo and Responses.

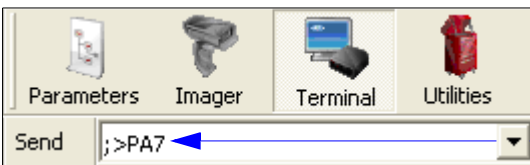

Enter the magic sequence in this text field and click **Send**.

Once the magic sequence has been sent, you can send text commands from the same text field.



Save Settings



Default to USB



Default to PS/2



Clear All Data



Clear XML Rules

Time Stamp

When **Time Stamp** is enabled, the time of each decode will be appended to data output as a preamble.

Note: The **Enable Time Stamp** command is an XML rule. To clear time stamp data, read the **Clear XML Rules** command.



M200_01

Enable Time Stamp



M199_01

Disable Time Stamp



M052_01

Clear XML Rules

Example: 01014627:ABCDEFGHIJKLMNOP

Day is: 01

Hour is: 01

Minutes are: 46

Seconds are: 27

Data is: ABCDEFGHIJKLMNOP



M188_02

Save
Settings



M049_03

Default
to USB



M060_03

Default
to PS/2



M071_01

Clear
All Data



M052_01

Clear
XML
Rules

Other Communications Settings in ESP

Some **ESP** Communications options are unique to the software, and do not have corresponding programming symbols. These options are explained below.

Reader Packet Format

Reader Packet Format	Raw*
	Raw*
	Packet

Data that is sent from the imager to the host in **Raw** format is sent without packet framing or check characters. **One-Way** communication is in a raw format, no response is expected from the host, and data is not resent.

Packetized data is sent with framing (a preamble communicating the amount of data to be transmitted, and a postamble containing error detection) and check characters, and a response is expected from the host. **Two-Way** communication is in packet format.

Reader to Host Packet Size

Reader to Host Packet Size	16384	(1 - 16384)
----------------------------	-------	-------------

The **Reader to Host Packet Size** is the amount of data (in bytes) that is sent to the host in packet format. This feature allows you to set the maximum allowable packet size.

Expect Host Response

Expect Host Response	Disabled*
	Disabled*
	Enabled

When **Expect Host Response** is enabled, the imager will re-transmit data if it doesn't receive acknowledgement from the host.

Reader Send Retry Count

Reader Send Retry Count	3	(1 - 2147483647)
-------------------------	---	------------------

Reader Send Retry Count sets the number of times the imager will re-transmit data before abandoning further send attempts. The minimum retry count is **1**, which represents the initial transmission.

Host Acknowledgement Timeout

Host Acknowledgement Timeout	0.015	Seconds
------------------------------	-------	---------

The **Host Acknowledgement Timeout** is the amount of time (in seconds) that the imager will wait for an acknowledgement from the host before re-sending data.

Store If Not Connected

Store if not Connected	Enabled*
	Disabled
	Enabled*

When this feature is enabled, the imager does not store data in non-volatile memory when there is not an active connection to a host. When disabled, the imager follows normal buffer operation.

Reconnect Timeout

Reconnect Timeout	90	Seconds
-------------------	----	---------

When **Auto Reconnect** is enabled, the imager will reconnect to the host whenever there is data to be sent, but only within the time limit (in seconds) set for **Reconnect Timeout**. See also [Transferring and Deleting Data](#) on page 4-18.

Max Connection Wait Time

Max Connection Wait Time	30	Seconds
--------------------------	----	---------

When a connection from the imager to the host is explicitly requested (such as when a Bluetooth Quick Connect Code is read), the imager will attempt a connection for the amount of time (in seconds) set for **Max Connection Wait Time**.

Background Bluetooth Connection

Background Bluetooth Connection	Disabled*
	Disabled*
	Enabled

Background Bluetooth Connection allows the user to begin decoding symbol data before a Bluetooth connection is established.

When this feature is disabled, the Bluetooth connection must be confirmed before decoding can begin.

Beep Before Bluetooth Connection

Beep before Bluetooth Connection	Disabled*
	Disabled*
	Enabled

When this feature is enabled, a second beep is emitted while reading the Bluetooth Quick Connect Code, but before the Bluetooth connection is established.

When this feature is disabled, the second beep is emitted upon connection to the Bluetooth Modem.



5 Symbologies

Contents

- Symbologies by ESP 5-2
- Aztec..... 5-3
- Codabar..... 5-4
- Codablock F 5-5
- Code 11 5-6
- Code 39..... 5-7
- Code 93..... 5-9
- Code 128..... 5-10
- Composite 5-11
- Data Matrix 5-12
- Interleaved 2 of 5..... 5-13
- Maxicode 5-14
- Matrix 2 of 5..... 5-15
- MicroPDF417..... 5-16
- MSI Plessey..... 5-17
- NEC 2 of 5..... 5-18
- PDF417 5-19
- Pharmacode 5-20
- Postal Symbologies..... 5-22
- QR Code..... 5-24
- GS1 DataBar 5-25
- UPC/EAN/JAN..... 5-26
- Symbology Identifier 5-27

This section describes the various symbol types that can be read and decoded by the imager. Symbologies are arranged alphabetically.

See <http://www.aimglobal.org/standards/aimpubs.asp> for additional information.

Symbologies by ESP

To make changes to configuration settings in the **Symbologies** tree control:

1. **Left click** on the **+** to expand the tree.

2. **Double click** on the parameter and click once in the selection box to view options.

3. Place your cursor in the selection box, scroll down to the setting you want to change and **click once** on the setting.

4. **Left click** again on the open screen to complete the selection.

5. **Right click** on the open screen and select **Save to Reader** to implement the command in the imager.

Parameters	
[-] Symbologies	
[-] 2D Symbologies	
[-] Data Matrix	Both
Data Matrix Improvements	Disabled
Data Matrix Rectangular	Enabled
Data Matrix ECC 0 - 140	Disabled
QR Code	Disabled
Aztec	Disabled
Maxicode	Disabled
[-] 1D Symbologies	
[-] Stacked Symbologies	
Codablock A	Disabled
Codablock F	Disabled
[-] PDF417	Enabled
Handle PDF417 Invalid Shift	Disabled
Micro PDF417	Disabled
Macro PDF417	Disabled
[-] Composite	Disabled
Symbology Identifier	Disabled
Image Transform	Standard*
	Standard*
	Mirrored Image
	Inverse

Aztec

Read the following symbols to enable/disable **Aztec** settings:

Aztec On



M273_01

Aztec Off (Default)



M272_01

Aztec by ESP

Aztec	Disabled*
	Disabled*
	Standard
	Inverse
	Both

Sample Aztec Symbol



Note: Aztec is available only in **Standard Mode**.



M188_02

Save
Settings

M049_03

Default
to USB

M060_03

Default
to PS/2

M071_01

Clear
All Data

M052_01

Clear
XML
Rules

Codabar

Read the following symbols to enable/disable **Codabar** settings:

Codabar On (Default)



M275_01

Codabar Off



M274_01

Codabar by ESP

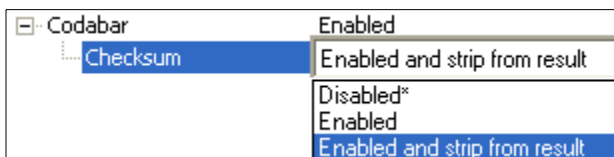

ESP allows you enable a checksum, or to enable a check sum and remove it from the decode result.

Sample Codabar Symbol



Note: Codabar is available only in **Standard Mode**.



Save Settings

M188_02



Default to USB

M049_03



Default to PS/2

M060_03



Clear All Data

M071_01



Clear XML Rules

M052_01

Codablock F

Read the following symbols to enable/disable **Codablock F** settings:

Codablock F On



M277_01

Codablock F Off (Default)



M276_01

Codablock by ESP

Note: **ESP** offers Codablock A in addition to Codablock F.

Codablock A	Disabled
Codablock F	Disabled*
	Disabled*
	Enabled

Important: When Codablock F and Code 128 are both enabled, there is some risks of mistakenly decoding a damaged Codablock F symbol as a Code 128 symbol. Therefore, whenever possible, Code 128 should be disabled when Codablock F is enabled.

Sample Codablock F Symbol



Note: Codablock F and Codablock A are available only in **Standard Mode**.



M188_02

Save
Settings



M049_03

Default
to USB



M060_03

Default
to PS/2



M071_01

Clear
All Data



M052_01

Clear
XML
Rules

Code 11

Read the following symbols to enable/disable **Code 11** settings:

**Code 11 Enabled with 2
Checksum Digits**



**Code 11 Disabled
(Default)**



**Enabled with 1 Checksum
Digit**



**Enabled with 2 Checksum Digits
and Stripped from Result**



**Enabled with 1 Checksum Digit
and Stripped from Result**



Code 11 by ESP

Note: “No Report” in **ESP** has the same meaning as “Stripped from Result”.

Code 11	Disabled*
	Disabled*
	Enabled with 2 checksum digits
	Enabled with 1 checksum digit
	Enabled with 2 checksum digits no report
	Enabled with 1 checksum digit no report

Sample Code 11 Symbol

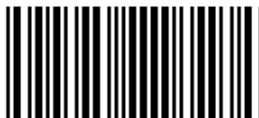

Note: Code 11 is available only in **Standard Mode**.

Code 39

Read the following symbols to enable/disable **Code 39** settings:

Code 39 On (Default)



M235_01

Code 39 Off



M234_01

Enable Checksum



M237_01

Disable Checksum (Default)



M236_01

Enable Checksum and Strip from Result



M238_01

Code 39 Extended Full ASCII On



M233_01

Code 39 Extended Full ASCII Off (Default)



M232_01

Code 39 Narrow Margins On



M390_01

Code 39 Narrow Margins Off (Default)



M389_01

Code 39 Trioptic On



M671_01

Code 39 Trioptic Off



M670_01



M188_02

Save
Settings

M049_03

Default
to USB

M060_03

Default
to PS/2

M071_01

Clear
All Data

M052_01

Clear
XML
Rules

Code 39 by ESP

Code 39	Enabled
Checksum	Enabled and strip from result
Extended Full ASCII	Disabled*
Narrow Margins	Enabled
Code 39 Trioptic	Enabled and strip from result

Sample Code 39 Symbol



Sample Code 39 Trioptic Symbol



Note: Code 39 is available only in **Standard Mode**.



Save Settings

M188_02



Default to USB

M049_03



Default to PS/2

M060_03



Clear All Data

M071_01



Clear XML Rules

M052_01

Code 93

Read the following symbols to enable/disable **Code 93** settings:

Code 93 On (Default)



M281_02

Code 93 Off



M280_01

Code 93 by ESP

Code 93	Enabled*
	Disabled
	Enabled*

Sample Code 93 Symbol



Note: Code 93 is available only in **Standard Mode**.



M188_02

Save Settings



M049_03

Default to USB



M060_03

Default to PS/2



M071_01

Clear All Data



M052_01

Clear XML Rules

Code 128

Read the following symbols to enable/disable **Code 128** settings:

Code 128 On (Default)



M283_01

Code 128 Off



M282_01

Code 128 Narrow Margins On



M392_01

Code 128 Narrow Margins Off (Default)



M391_01

Code 128 by ESP

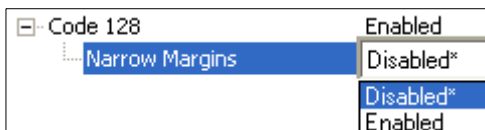

Sample Code 128 Symbol



Note: Code 128 is available only in **Standard Mode**.



Save Settings

M188_02



Default to USB

M049_03



Default to PS/2

M060_03



Clear All Data

M071_01



Clear XML Rules

M052_01

Composite

To read Composite symbols:

1. Enable the corresponding linear component.
2. Read the **Composite On** symbol below.

Important: Both the linear symbology and **Composite** must be enabled before the imager can fully decode a Composite symbol.

Composite On



Composite Off (Default)



Composite by ESP

Composite Linkage Control

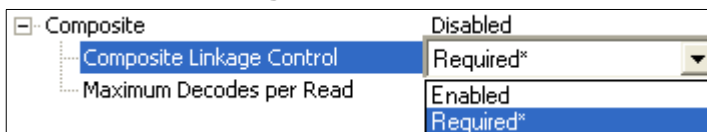

When **Composite Linkage Control** is set to **Required**, symbol data will only be output if both the 2D and 1D components of the symbol are decoded. When not required, symbol data will be output even when only one of the components is decoded.

Maximum Decodes per Read



Maximum Decodes per Read represents the maximum number of candidate symbols in the field of view that can be decoded during a read cycle. Note that decode speed will decrease as the **Maximum Decodes per Read** value is increased.

Sample Composite Symbol



Note: Composite is available only in **Standard Mode**.

Data Matrix

Read the following symbols to enable/disable **Data Matrix** settings:

Data Matrix Rectangle On



Data Matrix Rectangle Off



Data Matrix Inverse On



Data Matrix Inverse Off



Note: Data Matrix is available in both **Quadrus Only** and **Standard** modes.

Data Matrix ECC 0-140 On



Data Matrix ECC 0-140 Off (Default)



Note: Data Matrix ECC 0-140 is available for **MS-Q Quadrus** models only.

**Enable Data Matrix Improvements
(For Low Contrast and Binarized Symbols)**



Disable Data Matrix Improvements



Sample Data Matrix Symbol



Sample Rectangular Data Matrix Symbol



Data Matrix by ESP

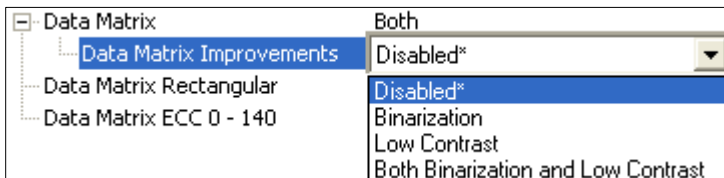

Save Settings



Default to USB



Default to PS/2



Clear All Data



Clear XML Rules

Interleaved 2 of 5

Read the following symbols to enable/disable **Interleaved 2 of 5** settings:

Interleaved 2 of 5 On (Default)



M244_01

Interleaved 2 of 5 Off



M243_01

Interleaved 2 of 5 Two Digits On



M246_01

Interleaved 2 of 5 Two Digits Off



M245_02

Interleaved 2 of 5 Four Digits On



M248_01

Interleaved 2 of 5 Four Digits Off



M247_01

Interleaved 2 of 5 by ESP

<input checked="" type="checkbox"/> Interleaved 2 of 5	Enabled
<input type="checkbox"/> Checksum	Disabled
<input checked="" type="checkbox"/> Length	2 Digit Disabled*
<input type="checkbox"/> Straight 2 of 5	2 and 4 Digit Disabled
	2 Digit Enabled
	4 Digit Enabled
	2 Digit Disabled*
	2 Digit Enabled 4 Digit Disabled
	2 Digit Disabled 4 Digit Enabled
	2 and 4 Digit Enabled

Sample Interleaved 2 of 5 Symbol



Note: Interleaved 2 of 5 is available only in **Standard Mode**.



M188_02

Save Settings



M049_03

Default to USB



M060_03

Default to PS/2



M071_01

Clear All Data



M052_01

Clear XML Rules

Maxicode

Read the following symbols to enable/disable **Maxicode** settings:

Maxicode On



M289_04

Maxicode Off (Default)



M288_01

Maxicode by ESP

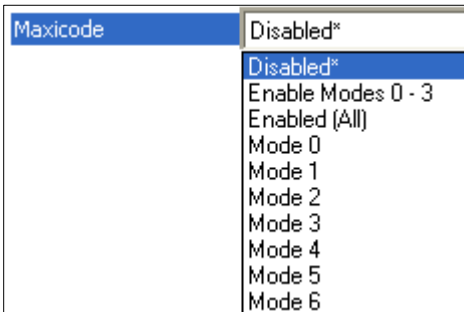

Sample Maxicode Symbol



Note: Maxicode is available only in **Standard Mode**.



Save Settings

M188_02



Default to USB

M049_03



Default to PS/2

M060_03



Clear All Data

M071_01



Clear XML Rules

M052_01

Matrix 2 of 5

Read the following symbols to enable/disable **Matrix 2 of 5** settings:

Matrix 2 of 5 On



M675_01

Matrix 2 of 5 Off (Default)



M674_01

Matrix 2 of 5 by ESP

Matrix 2 of 5	Disabled*
	Disabled*
	Enabled
	Enable Checksum
	Enable Checksum not output
	Enable decode 1 digit symbol
	Enable decode 2 digit symbol
	Enable decode 1 and 2 digit symbol
	Enable decode 1 digit with checksum
	Enable decode 2 digit with checksum
	Enable decode 1 and 2 digit with checksum
	Enable decode 1 digit w checksum not output
	Enable decode 2 digit w checksum not output
	Enable decode 1, 2 digit w checksum not output

Sample Matrix 2 of 5 Symbol



Note: Matrix 2 of 5 is available only in **Standard Mode**.



M188_02

Save
Settings

M049_03

Default
to USB

M060_03

Default
to PS/2

M071_01

Clear
All Data

M052_01

Clear
XML
Rules

MicroPDF417

Read the following symbols to enable/disable **MicroPDF417** settings:

MicroPDF417 On



M301_01

MicroPDF417 Off (Default)



M300_01

MicroPDF417 by ESP



Sample MicroPDF417 Symbol



Note: MicroPDF417 is available only in **Standard Mode**.



Save Settings

M188_02



Default to USB

M049_03



Default to PS/2

M060_03



Clear All Data

M071_01



Clear XML Rules

M052_01

MSI Plessey

Read the following symbols to enable/disable **MSI Plessey** settings:

MSI Plessey On



M291_01

MSI Plessey Off (Default)



M290_01

MSI Plessey by ESP



Sample MSI Plessey Symbol



Note: MSI Plessey is available only in **Standard Mode**.



M188_02

Save
Settings

M049_03

Default
to USB

M060_03

Default
to PS/2

M071_01

Clear
All Data

M052_01

Clear
XML
Rules

NEC 2 of 5

Read the following symbols to enable/disable **NEC 2 of 5** settings:

NEC 2 of 5 On



M673_01

NEC 2 of 5 Off (Default)



M672_01

NEC 2 of 5 by ESP

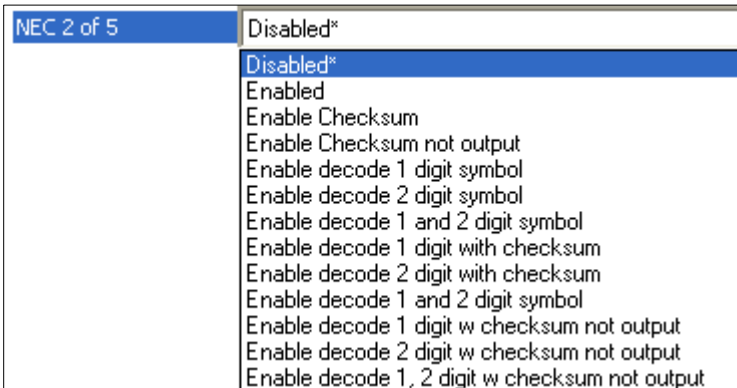

Note: NEC 2 of 5 is available only in **Standard Mode**.



Save Settings

M188_02



Default to USB

M049_03



Default to PS/2

M060_03



Clear All Data

M071_01



Clear XML Rules

M052_01

PDF417

Read the following symbols to enable/disable **PDF417** settings:

PDF417 On (Default)



M293_01

PDF417 Off



M292_01

MacroPDF417 On



M287_01

MacroPDF417 Off (Default)



M286_01

PDF417 by ESP

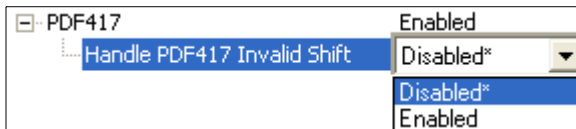

Sample PDF417 Symbol



Note: PDF417 is available only in **Standard Mode**.



M188_02

Save
Settings

M049_03

Default
to USB

M060_03

Default
to PS/2

M071_01

Clear
All Data

M052_01

Clear
XML
Rules

Pharmacode

Read the following symbols to configure **Pharmacode** settings:

Pharmacode On;
No Color, Standard Rules, Horizontal Decode, Normal Direction



M409_01

Pharmacode On;
Color, Relaxed Contrast, Horizontal Decode, Normal Direction



M410_01

Pharmacode On;
No Color, Standard Rules, Vertical Decode, Normal Direction



M411_01

Pharmacode On;
Color, Relaxed Contrast, Vertical Decode, Normal Direction



M412_01

Pharmacode On;
No Color, Standard Rules, Horizontal Decode, Reverse Direction



M413_01



Save Settings

M188_02



Default to USB

M049_03



Default to PS/2

M060_03



Clear All Data

M071_01



Clear XML Rules

M052_01

Pharmacode (cont.)

Pharmacode On;
Color, Relaxed Contrast, Horizontal Decode, Reverse Direction



Pharmacode On;
No Color, Standard Rules, Vertical Decode, Reverse Direction



Pharmacode On;
Color, Relaxed Contrast, Vertical Decode, Reverse Direction



Pharmacode Off (Default)



Pharmacode by ESP

Pharmacode	Disabled*
Minimum and Maximum Bars	Disabled*
Minimum Value	Enabled; no color bars; std rules; horiz; normal
Maximum Value	Enabled; color bars; relaxed rules; horiz; normal
	Enabled; no color bars; std rules; Vert; normal
	Enabled; color bars; relaxed rules; Vert; normal
	Enabled; no color bars; std rules; horiz; reverse
	Enabled; color bars; relaxed rules; horiz; reverse
	Enabled; no color bars; std rules; Vert; reverse
	Enabled; color bars; relaxed rules; Vert; reverse

Note: Pharmacode is available only in **Standard Mode**.

Postal Symbologies

Read the following symbols to enable/disable **Postal** settings:

Japan Post On



M253_01

Australian Post On



M252_01

KIX On



M254_01

Planet On



M256_01

Postnet On



M257_01

Postnet and Planet On



M255_01

Royal Mail On



M258_01

Disable All Postal Symbologies (Default)



M259_01



Save Settings

M188_02



Default to USB

M049_03



Default to PS/2

M060_03



Clear All Data

M071_01



Clear XML Rules

M052_01

Postal Symbologies by ESP

Postal	Disabled*
	Disabled*
	Australian
	Japan
	KIX
	Planet
	Postnet
	Royal

Sample Planet Symbol



Sample Postnet Symbol



Sample Royal Mail Symbol



Note: Postal symbologies are available only in **Standard Mode**.



Save
Settings

M188_02



Default
to USB

M049_03



Default
to PS/2

M060_03



Clear
All Data

M071_01



Clear
XML
Rules

M052_01

QR Code

Read the following symbols to enable/disable **QR Code** settings:

Standard QR Code On



M261_01

QR Code Off (Default)



M260_01

Inverse On



M262_01

Inverse and Standard On



M263_01

All QR Code On



M609_03

Inverse and Micro QR On



M687_03

QR Code by ESP

QR Code	Disabled*
	Disabled*
	Standard
	Inverse
	Both
	Micro QR Code
	QR Code and Micro Code
	Inverse Micro QR Code
	Inverse QR Code and Inverse MicroQR Code
	Enable All QR

Sample QR Code Symbol



Note: QR Code is available in both **Quadrus Only** and **Standard** modes.



Save Settings

M188_02



Default to USB

M049_03



Default to PS/2

M060_03



Clear All Data

M071_01



Clear XML Rules

M052_01

GS1 DataBar

Read the following symbols to enable/disable **DataBar** settings:

DataBar Limited On



M268_01

DataBar-14 and DataBar-14 Truncated On



M271_01

DataBar-14 Stacked On



M270_01

DataBar Expanded On



M269_01

All DataBar On



M267_01

All DataBar Off (Default)



M266_01

GS1 DataBar by ESP

RSS	Disabled*
	Disabled*
	RSS Expanded
	RSS Expanded Stacked
	RSS Limited
	RSS-14 Stacked and RSS-14 Stacked Omnidirectional
	Enabled (All)

Sample DataBar Limited Symbol



Sample DataBar-14 Truncated Symbol



Sample DataBar-14 Stacked Symbol



Sample DataBar Expanded Symbol



Sample DataBar-14 Symbol



Note: GS1 DataBar is available only in **Standard Mode**.

UPC/EAN/JAN

Read the following symbols to enable/disable **UPC/EAN/JAN** settings:

UPC On (Default)



M295_01

UPC Off



M294_01

UPC Narrow Margins On



M299_01

UPC Narrow Margins Off (Default)



M298_01

Note: Unless necessary, enabling **Narrow Margins** are not recommended.

UPC Extension On



M297_01

UPC Extension Off (Default)



M296_01

UPC/EAN/JAN by ESP

UPC	Enabled
Expansion	Enabled
Supplementals	Enabled
Narrow Margins	Disabled*
	Disabled*
	Enabled

Sample UPC-E Symbol



Note: UPC/EAN/JAN is available only in **Standard Mode**.



M188_02

Save Settings



M049_03

Default to USB



M060_03

Default to PS/2



M071_01

Clear All Data



M052_01

Clear XML Rules

Symbology Identifier

When **Symbology Identifier** is enabled, an AIM (Association for Automatic Identification and Mobility) preamble is added to decoded data output. This preamble identifies what kind of symbology has been decoded. The Symbology Identifier feature can be disabled by reading the **Clear XML Rules** symbol.



M308_03

Enable Symbology Identifier



M052_01

Clear XML Rules

Symbology Identifier by ESP

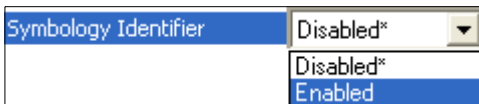

M188_02

Save
Settings



M049_03

Default
to USB



M060_03

Default
to PS/2



M071_01

Clear
All Data



M052_01

Clear
XML
Rules



6 I/O Parameters

Contents

I/O Parameters by ESP.....	6-2
Laser Target.....	6-3
Illumination.....	6-4
MS-Q Operational Feedback.....	6-5
Trigger and Button Programming.....	6-6
Beep and Vibrate Settings.....	6-8
Automatic Gain Control (AGC).....	6-9
LightRay Optics.....	6-11

This section contains information on how to set your imager to the most efficient and effective parameters for your application.

I/O Parameters by ESP

To make changes to configuration settings in the **I/O Parameters** menu tree control:

The screenshot shows a tree view of I/O parameters. The 'Unique Item Identifier (UII)' parameter is selected, and its dropdown menu is open, showing options: Disabled*, Enabled, Enabled with Error Message, Enabled with Pass Through, and Enabled with Error Message and Pass Through. Callouts provide instructions on how to interact with the tree and the dropdown menu.

Parameter	Value
I/O Parameters	
Noread Notification	Disabled
Laser Target	Enabled
Laser on before Capture	Disabled
Brightness	100
IR Illumination Control	Control Visible & IR with the Visible Settings
Button/Trigger Programming	
Button/Trigger Confirmation Time	
Beeper	
Volume	100
Duration	100
Separation	20
Beep on Good Read	Enabled
Automatic Gain Control (AGC)	Disabled
Auto Store Data Erase	Enabled
Auto Transfer	Enabled
Storage Mode	Send
Text Command Timeout	11000
Keyboard Inter Message Delay	0
Log Battery and Timestamp	0
Unique Item Identifier (UII)	Disabled*

1. **Left click** on the **+** to expand the tree.

4. **Left click** again on the open screen to complete the selection.
5. **Right click** on the open screen and select **Save to Reader** to implement the command in the imager.

2. **Double click** on the parameter and click once in the selection box to view options.
3. Place your cursor in the selection box, scroll down to the setting you want to change and **click once** on the setting.

Laser Target

In most applications the laser target will have no effect on symbol readability. Laser settings are typically a matter of user preference.



M054_01

This will disable the laser target. The LEDs and the ability to decode symbols will not be affected.

Laser Target Off



M055_01

Laser Target On

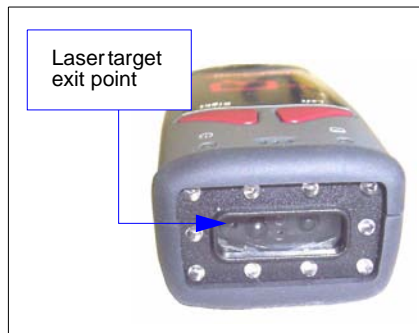

Laser Target Brightness

Read one of the following symbols to set the brightness of the laser target.



M058_01

High (Default)



M057_01

Medium



M056_01

Low

Laser Target by ESP

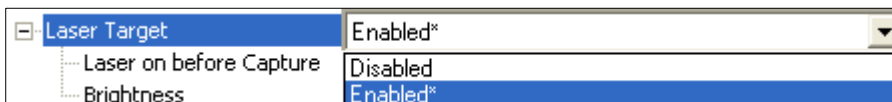

Note: **Laser On Before Capture** determines whether the laser target will be on or off just before the MS-Q captures and image, and is disabled by default.



M188_02

Save Settings



M049_03

Default to USB



M060_03

Default to PS/2



M071_01

Clear All Data



M052_01

Clear XML Rules

Illumination

The MS-Q Imager's illumination system is composed of four visible LEDs and six infrared (IR) LEDs as shown at right. Both visible and IR LEDs can be controlled independently. IR LEDs can also be set to low power.

For information about the laser target, see [Laser Target](#) on page 6-3.

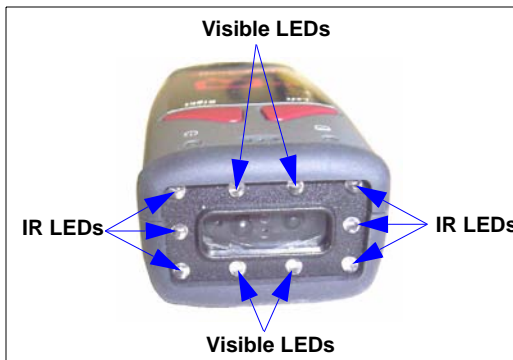

IR LEDs

Some inks may be incompatible with IR LEDs. If you experience trouble reading symbols printed in non-standard inks, try reducing the intensity of the IR LEDs by reading the **IR LEDs Low Intensity** symbol below. You can also disable the IR LEDs by reading the **IR LEDs Off, Visible LEDs On** symbol.



Turns off the near field IR LEDs. Does not turn off visible LEDs.

IR LEDs Low Intensity



Turns off IR LEDs and turns on visible LEDs.

IR LEDs Off, Visible LEDs On



Useful for highly reflective surfaces. Turns off near field IR LEDs.

Visible LEDs Off, IR LEDs On



Returns visible and IR LEDs to ON at 100% intensity.

Restore LEDs (Default)

Continuous Illumination

Note: Continuous Illumination is only supported in Rev 5 hardware and earlier.



Enable Continuous Illumination



Disable Continuous Illumination (Default)

Note: Continuous Illumination is only recommended for cabled readers, due to battery consumption.

MS-Q Operational Feedback

Imager Activity	☐ Memory LED (LEFT indicator)	⦿ Battery LED ^a (RIGHT indicator)	Sound
<i>Successfully Powered-On</i>	Flashes GREEN	Flashes GREEN	1 beep
<i>Successfully Enumerated with Host via USB Cable</i>	None	Solid GREEN	1 beep
<i>Attempting to Decode</i>	None	Battery Status	None
<i>Successful Decode and Cabled Data Transfer</i>	None	Solid GREEN	1 beep
<i>Successful Decode and Data Storage</i>	Memory Status	None	1 beep
<i>Batch Memory Full</i>	Solid RED	None	3 beeps
<i>Configuration Symbol Successfully Processed</i>	None	None	1 beep, pause, 1 beep
<i>Configuration Symbol Successfully Decoded but Not Processed</i>	None	None	6 beeps
<i>Attempting to Connect to Bluetooth</i>	Flashes BLUE	Solid GREEN	None
<i>Bluetooth Connection Failed</i>	None	None	4 beeps
<i>Bluetooth Connection Successful</i>	Flashes BLUE every 15 seconds	Flashes Battery Status every 15 seconds	None
<i>Sending Bluetooth Data</i>	Flashes Memory Status	None	None

a. When power is supplied via cable, the LED will remain green whenever the imager is active.

Left / Right Top LEDs

When not active, the MS-Q will flash battery or power status every 15 seconds. The colors will vary depending on the message the imager is sending.

- **GREEN** = 50-100% battery capacity OR 100% of memory available.
- **AMBER** = 20-50% battery capacity OR 20-99% of memory available.
- **RED** = 0-20% battery capacity or no memory available.
- **BLUE** = Bluetooth Mode

The MS-Q also emits beeps and/or vibrates to indicate specific information to the user. Refer to the table above to better understand MS-Q feedback.

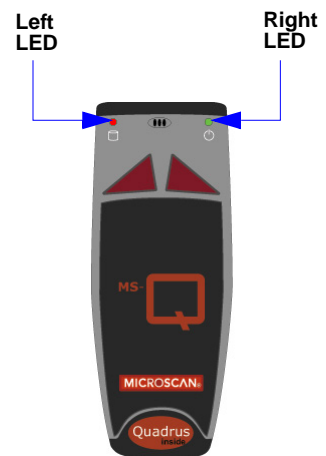

Trigger and Button Programming

Trigger and button functionality can be configured to read just near field, just far field, or both fields using the symbols shown below.

Handle Trigger Programming

Both Fields (Default)



M157_03

Near Field Only



M156_03

Far Field Only



M155_03

Handle Trigger Take Picture



M154_04

Left Button Programming

Both Fields (Default)



M178_01

Near Field Only



M177_01

Far Field Only



M176_01

Left Button Take Picture



M179_01

Disable Left Button



Q011_01

Enable Left Button Mode Switching (Quadrus Only / Standard)



Q001_01

Right Button Programming

Both Fields (Default)



M185_01

Near Field Only



M184_01

Far Field Only



M183_01

Right Button Take Picture



M186_01

Disable Right Button



Q012_01

See [Trigger Optimization](#) on page 7-7 for more trigger/button programming options.

Button/Trigger Confirmation Time

The **Button/Trigger Confirmation Time** is the amount of time that a button, trigger, or combination of the trigger and/or buttons, must be held down before the imager recognizes that a triggering event has occurred.

Button/Trigger Confirmation Time	
Handle	0
Left Top	300
Right Top	300
Left and Right Combo	0
Right and Handle Combo	0
Left and Handle Combo	0
All Three	0



M188_02

Save
Settings

M049_03

Default
to USB

M060_03

Default
to PS/2

M071_01

Clear
All Data

M052_01

Clear
XML
Rules

Beep and Vibrate Settings

Read the following symbols to configure beep and vibrate settings.

Beep / Vibrate



M108_01

**Vibrate Off / Beep On
(Default)**



M107_01

Vibrate On / Beep On



M109_01

Vibrate On / Beep Off

Beep Volume



M112_01

Beep Loud (Default)



M110_01

Beep Off



M111_01

Beep Quiet

Beep and Vibrate Settings by ESP

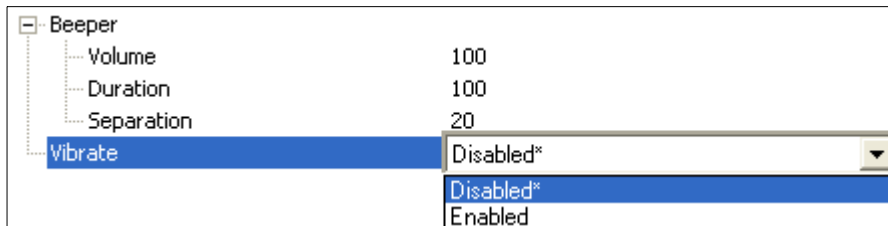

Note: **Duration** is the length of the beep in milliseconds with a configurable range of 0.000 to 2147483.750. **Separation** is the spacing in milliseconds between beeps, also with a configurable range of 0.000 to 2147483.750.



Save Settings

M188_02



Default to USB

M049_03



Default to PS/2

M060_03



Clear All Data

M071_01



Clear XML Rules

M052_01

Automatic Gain Control (AGC)

AGC is a system that controls gain in order to maintain high performance over a range of input levels. Gain is essentially the ratio of output to input. Gain settings affect how the MS-Q decodes symbols and captures images.

[-] Automatic Gain Control (AGC)	
AGC Selection	Use Decoder AGC*
AGC Frame Adjust Count	Use Decoder AGC*
Minimum Exposure	Use Imager AGC
Maximum Exposure	12
Minimum Gain	10
Maximum Gain	50
Gain Break Point	30

AGC Selection

AGC Selection	Use Decoder AGC*
	Use Decoder AGC*
	Use Imager AGC

The MS-Q has two different types of gain control. **Decoder AGC**, the default setting, is optimized for decoding 1D and 2D symbols. **Imager AGC** is optimized for capturing images.

AGC Frame Adjust Count

AGC Frame Adjust Count	0	Frames
------------------------	---	--------

AGC Frame Adjust Count sets the number of image frames captured and discarded before the main image capture. This feature gives the gain control time to adjust.

Minimum Exposure

Minimum Exposure	0	(0 - 100) %
------------------	---	-------------

Minimum Exposure is a percentage value that represents the minimum exposure allowed for image captures.

Maximum Exposure

Maximum Exposure	12	(0 - 100) %
------------------	----	-------------

Maximum Exposure is a percentage value that represents the maximum exposure allowed for image captures.

Automatic Gain Control (AGC)

Minimum Gain

Minimum Gain	10	▲ ▼	(0 - 100) %
--------------	----	--------	-------------

Minimum Gain is a percentage value that represents the minimum gain adjustment allowed for decoder or imager AGC.

Maximum Gain

Maximum Gain	50	▲ ▼	(0 - 100) %
--------------	----	--------	-------------

Maximum Gain is a percentage value that represents the maximum gain adjustment allowed for decoder or imager AGC.

Gain Break Point

Gain Break Point	30	▲ ▼	(0 - 100) %
------------------	----	--------	-------------

Gain Break Point is a percentage value that represents the point at which the imager stops automatic gain adjustment.

LightRay Optics

For Direct Part Mark applications or other situations that involve hard-to-read symbols, the MS-Q can be paired with an accessory called LightRay Optics. This accessory is easy to set up and easy to use. LightRay Optics comes in two series: the 100 and 200 series.

Important: LightRay Optics can only be used with the original (H1) MS-Q handle.

LightRay Accessory Options

Item	Part Number
LightRay 100 High Resolution	FIS-0001-0031G
LightRay 110 Standard Resolution	FIS-0001-0032G
Item	Part Number
LightRay 205 High Resolution	FIS-0001-0033G
LightRay 215 Standard Resolution	FIS-0001-0034G

MS-Q + LightRay Kits

LightRay 100 Series, Rev 5 Hardware (or Earlier)	Part Number
MS-Q Quadrus, High Resolution, USB (PS/2, RS-232), LightRay 100	FIS-6100-1011G
MS-Q Quadrus, High Resolution, Batch/Battery, LightRay 100	FIS-6100-1012G
MS-Q Quadrus, High Resolution, Bluetooth, LightRay 100	FIS-6100-1013G
MS-Q Quadrus, Standard Resolution, USB (PS/2, RS-232), LightRay 110	FIS-6100-1014G
MS-Q Quadrus, Standard Resolution, Batch/Battery, LightRay 110	FIS-6100-1015G
MS-Q Quadrus, Standard Resolution, Bluetooth, LightRay 110	FIS-6100-1016G
LightRay 200 Series, Rev 5 Hardware (or Earlier)	Part Number
MS-Q Quadrus, High Resolution, USB (PS/2, RS-232), LightRay 205	FIS-6100-2011G
MS-Q Quadrus, High Resolution, Batch/Battery, LightRay 205	FIS-6100-2012G
MS-Q Quadrus, High Resolution, Bluetooth, LightRay 205	FIS-6100-2013G
MS-Q Quadrus, Standard Resolution, USB (PS/2, RS-232), LightRay 215	FIS-6100-2014G
MS-Q Quadrus, Standard Resolution, Batch/Battery, LightRay 215	FIS-6100-2015G
MS-Q Quadrus, Standard Resolution, Bluetooth, LightRay 215	FIS-6100-2016G
LightRay 100 Series, Rev 6 Hardware	Part Number
MS-Q Quadrus, High Resolution, USB (PS/2, RS-232), LightRay 100	FIS-6100-1021G
MS-Q Quadrus, High Resolution, Bluetooth, LightRay 100	FIS-6100-1022G
MS-Q Quadrus, Standard Resolution, USB (PS/2, RS-232), LightRay 110	FIS-6100-1023G
MS-Q Quadrus, Standard Resolution, Batch/Battery, LightRay 110	FIS-6100-1024G
LightRay 200 Series, Rev 6 Hardware	Part Number
MS-Q Quadrus, High Resolution, USB (PS/2, RS-232), LightRay 205	FIS-6100-2021G
MS-Q Quadrus, High Resolution, Batch/Battery, LightRay 205	FIS-6100-2022G
MS-Q Quadrus, High Resolution, Bluetooth, LightRay 205	FIS-6100-2023G

Setup

Choose Field of View



M156_03
Near Field High Resolution (100)



M155_03
Far Field Standard Resolution (110)



M156_03
Near Field High Resolution (205)



M155_03
Far Field Standard Resolution (215)

Set Up Illumination



Laser On, LEDs On, 100% (100, 110)



Laser Off, LEDs On, 100% (100, 110)



Laser On, Visible LEDs Off, IR LEDs On, 100% (205, 215)



Laser Off, Visible Off, IR On, 100% (205, 215)

Assembly (100 Series)

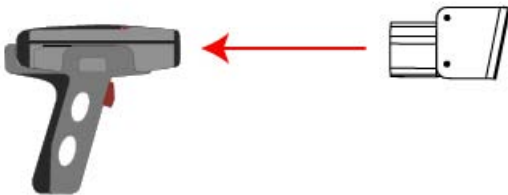

- Place the 100 Series LightRay Optic attachment over the face of the MS-Q Imager.

- The plastic body of the LightRay Optics device should be pressed firmly against the face of the imager, allowing minimum slippage.
- Be sure that the device and the imager's face are aligned as precisely as possible.



Assembly (200 Series)

- Place the 200 Series LightRay Optics attachment over the face of the MS-Q Imager.
- The plastic body of the LightRay Optic device should be pressed firmly against the face of the imager, allowing minimum slippage.
- But sure that the device and the imager's face are aligned as precisely as possible.



Reading Symbols (100 Series)

- For best results, begin triggering before the LightRay Optic has come in contact with the surface or substrate.
- Center the symbol in the LightRay Optic guide's cutout.

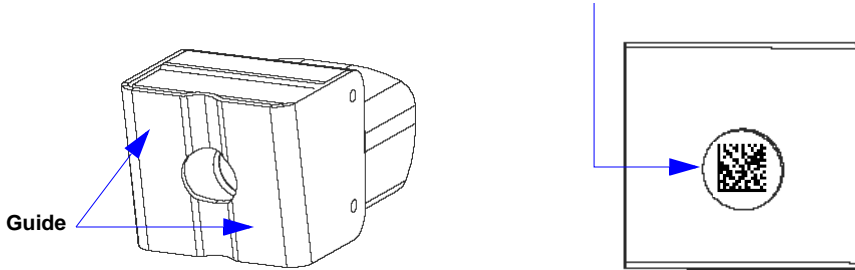

Reading Symbols (200 Series)

- For best results, begin triggering before the LightRay Optic has come in contact with the surface or substrate.
- Position the symbol equidistant from both of the 200 Series LightRay Optic's guides.

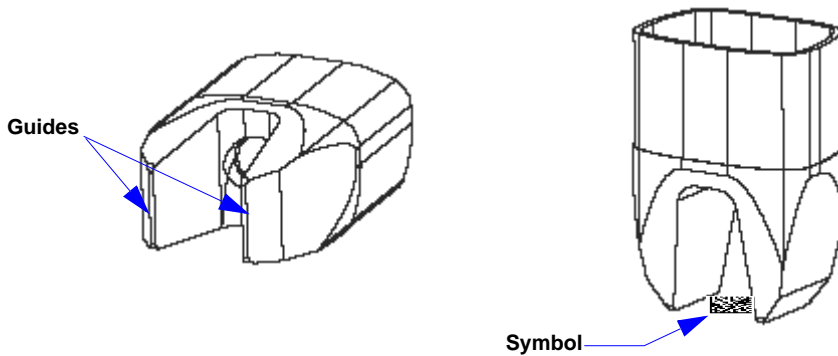

LightRay Optics by ESP

The MS-Q Imager can also be configured and optimized for LightRay operation using **ESP**.

Click on the series you are using. You can either use the radio buttons (“100 Series” and “200 Series”) or click directly on the pictures. The image of the selected model will glow, as shown in the example below.

Select Light Ray Optics Series

Illumination

100 Series 200 Series (200 Series selected)

Optics

HR Near Field (100, 205) SR Far Field (110, 215) Both

VGA Fast Read Mode Laser Target On

Trigger / Button: Handle Trigger

UII (Unique Item Identifier)

Enable Append Error Message

Pass Through

Send Settings Send and Save

Choose the field of view and resolution that match your LightRay Optics model.

Only available for Rev 5 hardware or earlier.

Enable or disable UII functionality. (See **UII Mode Settings by ESP** on page 10-5.)

Configure the handle trigger or left and right buttons with **VGA Fast Read** (if Rev 5 hardware or earlier) and **Laser Target** options.

Send LightRay settings to the imager, or **Send and Save** all settings.

■ 7 *Advanced Operations*

Contents

Dual Optics	7-2
VGA and Megapixel Settings.....	7-3
Select Region of Interest	7-4
Set Targeting Zone Tolerances	7-5
IP Modes	7-6
Trigger Optimization	7-7
Trigger Optimization by ESP	7-15
Continuous Operations.....	7-18
Symbol Background	7-20
Set Decode Time.....	7-21
Button Stay-Down Time.....	7-22
Mirroring	7-23
Motion Detection.....	7-24
Auto White Balance.....	7-25
Symbol Readability Index	7-26

This section introduces several settings that can be applied to speed up processing or improve readability in various circumstances.

Dual Optics

The MS-Q Imager's dual field optical system can read small 2D symbols as well as larger 1D symbols. It decodes the near and far fields simultaneously. The near field lens is for smaller symbols (optimal focal point: 4 inches) and the far field lens is for larger symbols (optimal focal point: 9 inches). Move the MS-Q closer to read smaller symbols and farther away to read larger symbols. The full MS-Q decode zone is 2 inches to 20 or more inches.

SXGA (Megapixel) Imaging Area

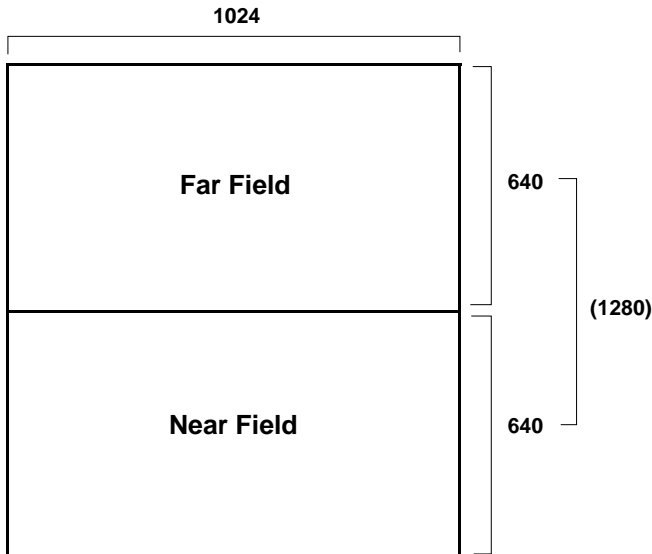

In standard SXGA mode, the megapixel optics are divided into far and near field decode zones. Each decode zone is 1024 x 640 pixels. This mode has the highest resolution and provides the widest working range for decoding 1D and 2D symbols of all densities. Image processing time is slightly greater if the entire area (1280 x 1024) is used, but various adjustments can significantly reduce processing time.

If only near field is used (smaller, denser symbols), the far field image can be ignored. If only far field is used (larger, less dense symbols), the near field image can be ignored.

Image processing time can be reduced still further by specifying a **Select Region of Interest** within the imaging area (page 7-4).

VGA Imaging Area

Important: VGA is only supported in Rev 5 hardware and earlier.

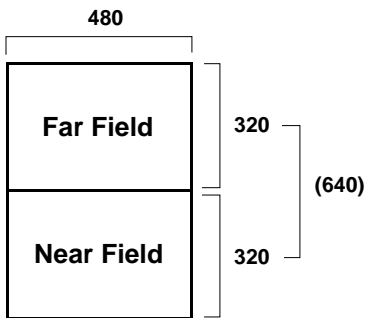

In VGA mode, the imager's 1.3 million pixels are sampled on a 4-to-1 basis. This pixel sampling dramatically reduces image processing time. Because a VGA image is created by pixel sampling, its resolution is not as high as that of an SXGA image.

VGA and Megapixel Settings

Processing speed can be increased dramatically by changing the imager's **SXGA** (1280 x 1024) setting to **VGA** (640 x 480). This feature is intended for use with 1D symbols and 2D symbols with larger elements. VGA settings are not recommended for decoding high-density symbols.

Important: VGA is only supported in **Rev 5** hardware and earlier.

Enable VGA (640 x 480)



M202_03

Enable SXGA (1280 x 1024)



M201_03



M188_02

Save Settings



M049_03

Default to USB



M060_03

Default to PS/2



M071_01

Clear All Data



M052_01

Clear XML Rules

Select Region of Interest

You can speed up your decode rate and lower your chances of reading the wrong symbol by narrowing the region of interest—the pixel area that is evaluated during a read attempt.

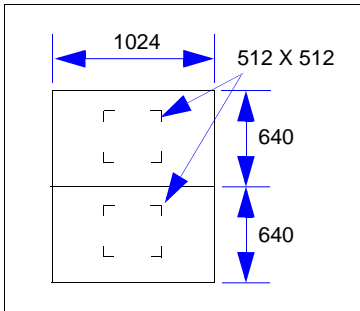

If your application uses only 1D symbols, you can narrow the imager's 640 axis to 200 pixels. Since only a narrow strip of the imager's field of view is required to decode a 1D symbol, 200 pixels is sufficient. The area above and below the 200 pixels is ignored, reducing the amount of image processing required, and increasing decode speed.

The diagram to the left represents the imager array (1024 x 640 for far field and 1024 x 640 for near field). In the default decode zone, all 1024 x 640 pixels are candidates for decoding.

You can experiment by reading in any of the symbols below and testing your new decode zone against your application.

Note: This feature applies to SXGA only.

1-Dimensional Symbols Only (1024 x 200 pixels)



M209_01

Small 2-Dimensional Symbols (480 x 480 pixels)



M210_01

Medium 2-Dimensional Symbols (512 x 512 pixels)



M211_01

Large 2-Dimensional Symbols (640 x 640 pixels)



M212_01

Default 2-Dimensional Symbols (1024 x 640 pixels) Casts the broadest possible FOV.



M213_01



Save
Settings

M188_02



Default
to USB

M049_03



Default
to PS/2

M060_03



Clear
All Data

M071_01



Clear
XML
Rules

M052_01

Set Targeting Zone Tolerances

Targeting Zone Tolerance is particularly useful in environments where closely spaced symbols of various sizes need to be precisely targeted. It allows the imager to narrow the field of view relative to the size of a symbol, and to determine the distance the laser target must be from the symbol for a decode event to occur.

This is accomplished by counting the number of pixels across a symbol and comparing that number with the distance (in pixels) of the laser target from the edge of the symbol (x 2). The exact formula is shown in the diagram to the right.

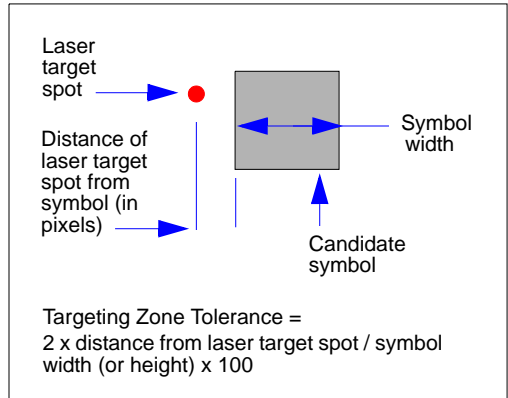

For example, a target tolerance of 100 would require the laser target spot to be no more than half the dimension (width or height) of the candidate symbol. So, for a symbol that is 100 pixels across, the laser target spot would have to be within 50 pixels on either side. A 100-pixel symbol with a tolerance of 50 would have to be within 25 pixels on either side of the symbol.

The configuration symbols below represent a range of tolerances, 50 being the most precise (least tolerant) and 1600 being the least precise (most tolerant). If you set the imager to 50% tolerance, you will need to aim the laser target so that the spot is directly on the candidate symbol.

Read one of the symbols below to set the desired tolerance.



M189_01

50



M190_01

75



M191_01

100



M192_01

125



M193_01

150



M195_01

200



M194_01

400



M196_01

1600 (Default)



M188_02

Save Settings



M049_03

Default to USB



M060_03

Default to PS/2



M071_01

Clear All Data



M052_01

Clear XML Rules

IP Modes

Quadrus Only Mode



Q002_01

Quadrus Only Mode should be applied to most applications, including Direct Part Mark.

Quadrus Mode 1



Q003_01

Quadrus Mode 1 should be applied to large, low contrast symbols like the one shown below.

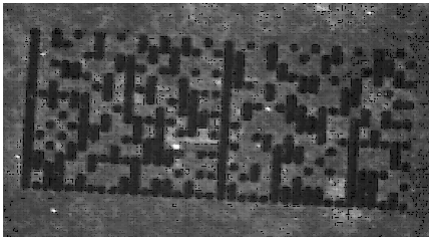

Standard Mode



Q004_01

Standard Mode, while not recommended for DPM applications, can be applied to most symbologies.



Save Settings

M188_02



Default to USB

M049_03



Default to PS/2

M060_03



Clear All Data

M071_01



Clear XML Rules

M052_01

Trigger Optimization

You can program all triggers/buttons, or each trigger/button individually, so that it is optimized for symbologies of certain densities and sizes. The table below describes the various configuration settings that can be obtained (**A1** through **D3**) by reading the symbols in the subsequent tables.

Optimization Guide

Important: VGA “Fast Processing” is only supported in **Rev 5** hardware and earlier.

	High and Low Density Symbols <i>Near and Far Field</i>		High Density Symbols <i>Near Field</i>	Low Density Symbols <i>Far Field</i>	
 <p>Region of Interest</p>	A1 - SXGA Mode Near Field On Far Field On NF Resolution: 1024 x 640 FF Resolution: 1024 x 640 Decode Try Time: Long	B1 - SXGA Mode Near Field On Far Field On NF Resolution: 1024 x 640 FF Resolution: 1024 x 640 Decode Try Time: Normal	C1 - SXGA Mode Near Field On Far Field Off NF Resolution: 1024 x 640 FF Resolution: NA Decode Try Time: Normal	D1 - SXGA Mode Near Field Off Far Field On NF Resolution: NA FF Resolution: 1024 x 640 Decode Try Time: Normal	
	A2 - SXGA Mode Near Field On Far Field On NF Resolution: 832 x 640 FF Resolution: 1024 x 640 Decode Try Time: Normal	B2 - SXGA Mode Near Field On Far Field On NF Resolution: 640 x 512 FF Resolution: 832 x 640 Decode Try Time: Short	C2 - SXGA Mode Near Field On Far Field Off NF Resolution: 640 x 640 FF Resolution: NA Decode Try Time: Normal	D2 - SXGA Mode Near Field Off Far Field On NF Resolution: NA FF Resolution: 832 x 512 Decode Try Time: Normal	
	A3 - SXGA Mode Near Field On Far Field On NF Resolution: 480 x 480 FF Resolution: 640 x 480 Decode Try Time: Short				
Fast Processing (VGA Mode)		B3 - VGA Mode Near Field On Far Field On NF Resolution: 480 x 320 FF Resolution: 480 x 320 Decode Try Time: Short	C3 - VGA Mode Near Field On Far Field Off NF Resolution: 480 x 320 FF Resolution: NA Decode Try Time: Short	D3 - VGA Mode Near Field Off Far Field On NF Resolution: NA FF Resolution: 480 x 320 Decode Try Time: Short	

Definitions

Symbol Density: Width of the narrowest bar of a linear (1D) symbol or the side of an individual element (cell or module) of a Data Matrix symbol.

Resolution: The number of pixels available for decoding in a given area.

Decode Try Time: The time spend attempting to decode a given symbol.

Region of Interest: The pixel area in the imager that is evaluated during a read attempt.

Use the tables on the following pages to program your MS-Q’s handle trigger or top buttons for the fields of view and symbol densities that best match your application. See [Optimization Parameters](#) for more detailed explanations of each setting, and for examples of conditions in which you would use each setting (page 7-13).

Global Optimization

Important: VGA “Fast Processing” is only supported in Rev 5 hardware and earlier.

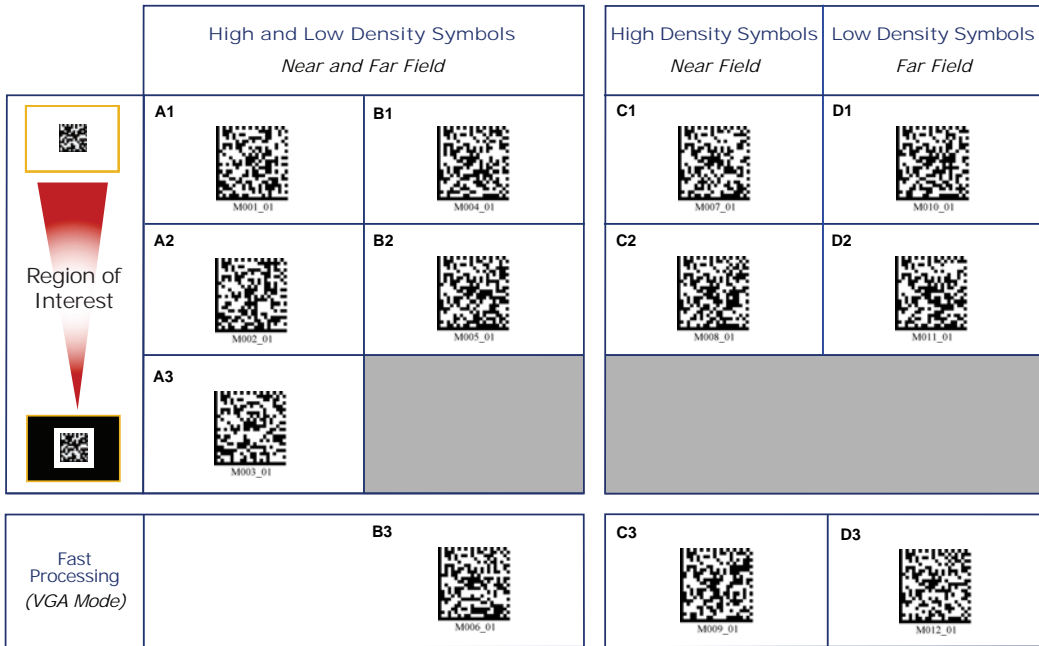

Note: See [Optimization Parameters](#) for more detailed explanations of each setting, and for examples of conditions in which you would use each setting (page 7-13).



Save Settings

M188_02



Default to USB

M049_03



Default to PS/2

M060_03



Clear All Data

M071_01



Clear XML Rules

M052_01

Handle Trigger Optimization

Important: VGA “Fast Processing” is only supported in Rev 5 hardware and earlier.

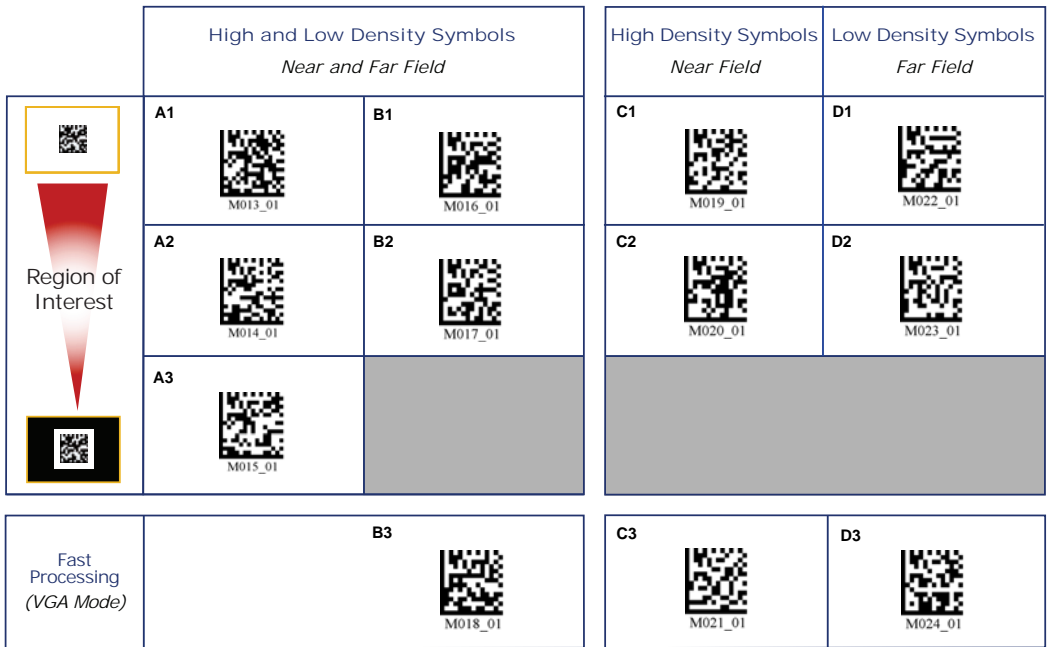

Handle Trigger Programming

Both Fields (Default)



Near Field Only



Far Field Only



Handle Trigger Take Picture



Disable Handle Trigger



Left Button Optimization

Important: VGA “Fast Processing” is only supported in Rev 5 hardware and earlier.

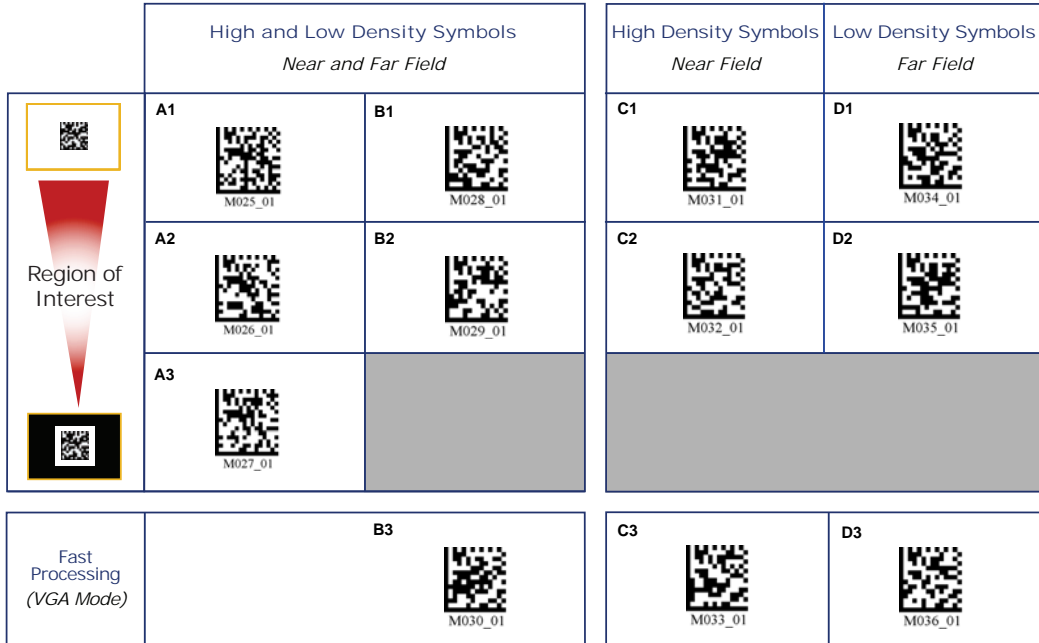

Left Button Programming

Both Fields (Default)



Near Field Only



Far Field Only



Left Button Take Picture



Disable Left Button





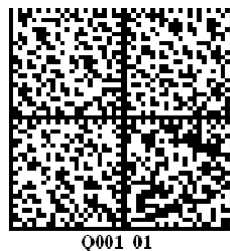









**Enable Left Button Mode Switching
(Quadrus Only / Standard)**



Right Button Optimization

Important: VGA “Fast Processing” is only supported in Rev 5 hardware and earlier.

	High and Low Density Symbols <i>Near and Far Field</i>		High Density Symbols <i>Near Field</i>	Low Density Symbols <i>Far Field</i>	
 <p>Region of Interest</p>	A1  M037_01	B1  M040_01	C1  M043_01	D1  M046_01	
	A2  M038_01	B2  M041_01	C2  M044_01	D2  M047_01	
	A3  M039_01				
Fast Processing <i>(VGA Mode)</i>	B3  M042_01		C3  M045_01	D3  M048_01	

Right Button Programming

Both Fields (Default)



Near Field Only



Far Field Only



Right Button Take Picture



Disable Right Button



Continuous Trigger Optimization

Important: VGA “Fast Processing” is only supported in Rev 5 hardware and earlier.

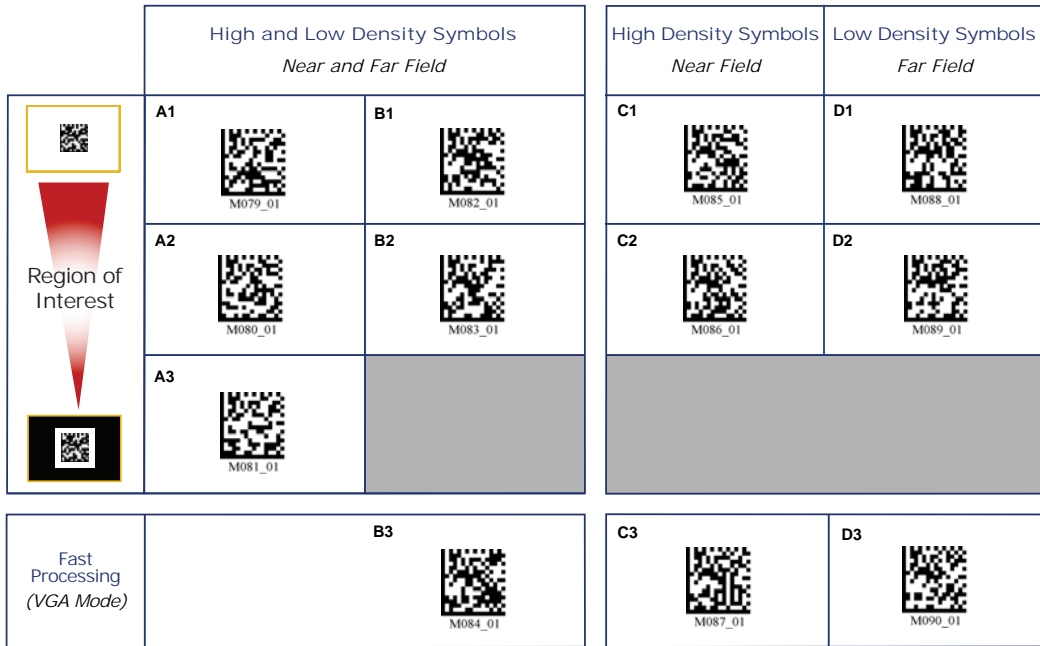

Continuous Trigger Programming

Both Fields



Near Field Only



Far Field Only



Disable Continuous Trigger (Default)



Save Settings



Default to USB



Default to PS/2



Clear All Data



Clear XML Rules

Optimization Parameters

The following 12 settings (**A1** through **D3**) allow you to optimize the imager's performance in your particular application environment. Try several settings to familiarize yourself with the differences between the 12 options.

High and Low Density Symbols <i>Near and Far Field</i>			
Use A1 if you are reading a variety of symbol sizes and densities, and you are more concerned with decode capability than with decode speed.	<table border="1" style="width: 100%;"> <tr> <td style="vertical-align: top;">A1: Reads high and low density symbols at high resolution in near and far fields; spends 675 mS attempting to decode the symbol; large region of interest that extends beyond the symbol.</td> <td style="vertical-align: top;">B1: Reads high and low density symbols in near and far fields at high resolution in both fields; spends 375 mS attempting to decode the symbol; large region of interest that extends beyond the symbol.</td> </tr> </table>	A1: Reads high and low density symbols at high resolution in near and far fields; spends 675 mS attempting to decode the symbol; large region of interest that extends beyond the symbol.	B1: Reads high and low density symbols in near and far fields at high resolution in both fields; spends 375 mS attempting to decode the symbol; large region of interest that extends beyond the symbol.
A1: Reads high and low density symbols at high resolution in near and far fields; spends 675 mS attempting to decode the symbol; large region of interest that extends beyond the symbol.	B1: Reads high and low density symbols in near and far fields at high resolution in both fields; spends 375 mS attempting to decode the symbol; large region of interest that extends beyond the symbol.		
Use A2 if you are reading a variety of symbol sizes and densities, and you require dependable but moderately fast decodes.	<table border="1" style="width: 100%;"> <tr> <td style="vertical-align: top;">A2: Reads high and low density symbols in near and far fields at medium-high resolution in near field and high resolution in far field; spends 375 mS attempting to decode the symbol; region of interest that extends somewhat beyond the symbol.</td> <td style="vertical-align: top;">B2: Reads high and low density symbols in near and far fields at medium-low resolution in near field and medium-high resolution in far field; spends 250 mS attempting to decode the symbol; region of interest that extends somewhat beyond the symbol.</td> </tr> </table>	A2: Reads high and low density symbols in near and far fields at medium-high resolution in near field and high resolution in far field; spends 375 mS attempting to decode the symbol; region of interest that extends somewhat beyond the symbol.	B2: Reads high and low density symbols in near and far fields at medium-low resolution in near field and medium-high resolution in far field; spends 250 mS attempting to decode the symbol; region of interest that extends somewhat beyond the symbol.
A2: Reads high and low density symbols in near and far fields at medium-high resolution in near field and high resolution in far field; spends 375 mS attempting to decode the symbol; region of interest that extends somewhat beyond the symbol.	B2: Reads high and low density symbols in near and far fields at medium-low resolution in near field and medium-high resolution in far field; spends 250 mS attempting to decode the symbol; region of interest that extends somewhat beyond the symbol.		
Use A3 if you are reading a variety of symbol sizes and densities, but you are concerned mainly with obtaining fast decodes.	<table border="1" style="width: 100%;"> <tr> <td style="vertical-align: top;">A3: Reads high and low density symbols at low resolution in near field and medium-low resolution in far field; spends 250 mS attempting to decode the symbol; region of interest limited to the symbol and its quiet zone.</td> <td style="background-color: #cccccc;"></td> </tr> </table>	A3: Reads high and low density symbols at low resolution in near field and medium-low resolution in far field; spends 250 mS attempting to decode the symbol; region of interest limited to the symbol and its quiet zone.	
A3: Reads high and low density symbols at low resolution in near field and medium-low resolution in far field; spends 250 mS attempting to decode the symbol; region of interest limited to the symbol and its quiet zone.			
Use B1 if you are reading a variety of symbol sizes and densities, and you need reliable, moderately fast decodes.	<table border="1" style="width: 100%;"> <tr> <td style="vertical-align: top;">B3: Reads high and low density symbols in near and far fields at low resolution in both fields; spends 250 mS attempting to decode the symbol; small region of interest limited to the symbol and its quiet zone. (Rev 5 hardware and earlier only.)</td> </tr> </table>	B3: Reads high and low density symbols in near and far fields at low resolution in both fields; spends 250 mS attempting to decode the symbol; small region of interest limited to the symbol and its quiet zone. (Rev 5 hardware and earlier only.)	
B3: Reads high and low density symbols in near and far fields at low resolution in both fields; spends 250 mS attempting to decode the symbol; small region of interest limited to the symbol and its quiet zone. (Rev 5 hardware and earlier only.)			
Use B2 if you are reading a variety of symbol sizes and densities, and you want a balance of decode reliability and decode speed.			
Use B3 if you are reading a variety of symbol sizes and densities, but you want the fastest decode speed available.			

Note: See the [Optimization Guide](#) for definitions of optimization terminology (page 7-7).

Optimization Parameters (cont.)

High Density Symbols <i>Near Field</i>	Low Density Symbols <i>Far Field</i>
<p>C1: Reads high density symbols only at high resolution in near field only; spends 375 mS attempting to decode the symbol; large region of interest that extends beyond the symbol.</p>	<p>D1: Reads low density symbols only at high resolution in far field only; spends 375 mS attempting to decode the symbol; large region of interest that extends beyond the symbol.</p>
<p>C2: Reads high density symbols only at medium-low resolution in near field only; spends 375 mS attempting to decode the symbol; region of interest that extends somewhat beyond the symbol.</p>	<p>D2: Reads low density symbols only at medium resolution in far field only; spends 375 mS attempting to decode the symbol; region of interest that extends somewhat beyond the symbol.</p>
Empty cell for visual consistency	
<p>C3: Reads high density symbols only, at low resolution in near field only; spends 250 mS attempting to decode the symbol; small region of interest limited to the symbol and its quiet zone. (Rev 5 hardware and earlier only.)</p>	<p>D3: Reads low density symbols only at low resolution in far field only; spends 250 mS attempting to decode the symbol; small region of interest limited to the symbol and its quiet zone. (Rev 5 hardware and earlier only.)</p>

Use **C1** if you are reading small or medium high density symbols and you need reliable and moderately fast decodes.

Use **C2** if you are reading small or medium high density symbols and you are more concerned with decode speed than decode reliability.

Use **C3** if you are reading small or medium high density symbols and you are most concerned with obtaining fast decodes.

Use **D1** if you are reading medium or large low density symbols and you want reliable and moderately fast decodes.

Use **D2** if you are reading medium or large low density symbols and you want a balance of decode reliability and speed.

Use **D3** if you are reading medium or large low density symbols and you are more concerned with fast decodes than reliability.

Note: See the [Optimization Guide](#) for definitions of optimization terminology (page 7-7).

Trigger Optimization by ESP

You can use **ESP's Imager** view to set operation parameters for the handle trigger and both buttons.



Single click the **Imager** button to begin.

ESP Optimization Matrix

Trigger/Button Summary
Trigger/Button Configuration
Trigger Optimization

Trigger: Handle Trigger
Choose which trigger or button to optimize from this dropdown menu.

	High and Low Density Symbols <i>Near and Far Field</i>		High Density Symbols <i>Near Field</i>	Low Density Symbols <i>Far Field</i>
	<p style="font-size: small;">Region of Interest</p>	A1	B1	C1
	A2	B2	C2	D2
	A3		Each button corresponds with a setting on the Optimization Guide matrix (page 7-7).	

Note: **VGA Fast Processing** settings **B3**, **C3**, and **D3** are shown here when a Rev 5 (or earlier) MS-Q model is connected. VGA settings are not supported in Rev 6 MS-Q models.

Configuration Status

Handle Trigger:	Trigger Optimization B1
Right Button:	Read Symbols in Both Fields
Left Button:	Enable Button Mode Switching (Quadrus / Standard)
Left and Right:	Enable Button Mode Switching (Adaptive / Fixed)
Continuous:	Idle

The **Configuration Status** display shows current settings for each trigger or button.

Trigger/Button Configuration

In the **Trigger/Button Configuration** view you can set the same optimization parameters from a list, and you can also set additional parameters.

The screenshot shows the 'Trigger/Button Configuration' tab in a software interface. At the top, there are three tabs: 'Trigger/Button Summary', 'Trigger/Button Configuration', and 'Trigger Optimization'. Below the tabs, there is a 'Button:' dropdown menu currently set to 'Handle Trigger'. A callout box points to this dropdown with the text: 'Choose which trigger or button to optimize from this dropdown menu.' Below the dropdown is a large 'Function List' scrollable area containing various options such as '* Read Symbols in Both Fields', 'Read Symbols with Far-Field Only', 'Transfer All Data', and several 'Trigger Optimization' options (A1-A3, B1-B3, C1-C3, D1-D3). A callout box points to the 'Trigger Optimization B3' option with the text: 'Each trigger optimization option corresponds with a setting on the **Optimization Guide** (page 7-7)'. At the bottom of the interface is a 'Configuration Status' section with several rows of settings: 'Handle Trigger: Trigger Optimization B3', 'Right Button: Read Symbols in Both Fields', 'Left Button: Enable Button Mode Switching', 'Left and Right: Enable Button Mode Switching (Adaptive / Fixed)', and 'Continuous: Upload All'. A callout box points to this section with the text: 'The **Configuration Status** display shows current settings for each trigger or button.'

Trigger/Button Summary

The **Trigger/Button Summary** view has the same Configuration Status information as the other two views, but it supplements that information with a diagram of the MS-Q Imager.

Trigger/Button Summary
Trigger/Button Configuration
Trigger Optimization

Auto Sync Settings with Reader

Handle Trigger

Right Button

Left Button

Configuration Status

Handle Trigger:	Trigger Optimization B1
Right Button:	Read Symbols in Both Fields
Left Button:	Enable Button Mode Switching (Quadrus / Standard)
Left and Right:	Enable Button Mode Switching (Adaptive / Fixed)
Continuous:	Idle

This graphic interface orients the user to the location of the imager's handle trigger and the left and right top buttons.

Configuration Status shows current settings for each trigger or button.

Continuous Operations

Continuous Read

Read any of the following symbols to enable or disable Continuous Read features.

Note: Continuous Read modes are only recommended for short term use because of battery consumption. See [Sleep Mode Timeout](#) on page 4-12.



M138_02

Near and Far Field



M140_02

Near Field Only



M139_02

Far Field Only



M141_03

Continuous Read Off (Default)

Continuous Read, Sleep Timeout

Cabled

Read one of the symbols below to set the amount of time the cabled imager will operate in Continuous Read before entering Sleep Mode.



M136_01

Cabled - 2 Hours



M137_01

Cabled - Always On (Default)

Uncabled

Read one of the symbols below to set the amount of time the uncabled imager will operate in Continuous Read before entering Sleep Mode.



M145_01

Uncabled - 5 Minutes (Default)



M146_01

Uncabled - 15 Minutes



M147_01

Uncabled - 30 Minutes

Continuous Read, Trigger Delays

Read the following symbols to set the delay time between decodes.



M142_01

**0 Seconds
(Default)**



M143_01

1 Second



M144_01

3 Seconds

Continuous Read, Duplicate Read Delays



M222_01

**0 Seconds
(Default)**



M223_01

1 Second



M224_01

3 Seconds



M141_02

Continuous Read Off (Default)



M188_02

Save
Settings



M049_03

Default
to USB



M060_03

Default
to PS/2



M071_01

Clear
All Data



M052_01

Clear
XML
Rules

Symbol Background

“Symbol Background” refers to the color of the substrate on which a symbol is printed or marked. In the default state, **Reverse Background On** means that both types of symbols, dark-on-light and light-on-dark, will be read. **Reverse Background Off** will speed up image processing if only dark symbols on light backgrounds are being read.

Reverse Background On (Default)



Reverse Background Off

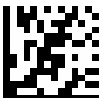

Sample Data Matrix Symbol (Light Background)



Sample Data Matrix Symbol (Dark Background)



Save
Settings

M188_02



Default
to USB

M049_03



Default
to PS/2

M060_03



Clear
All Data

M071_01



Clear
XML
Rules

M052_01

Set Decode Time

The MS-Q's default settings are designed for optimal, general purpose performance with high quality symbols on typical surfaces. For poor quality symbols, more decode time may be required. You can control the amount of time the imager spends on each decode attempt before abandoning the current attempt and beginning a new attempt.

Short Decode Time



Normal Decode Time (Default) (approx. 375 mS)



Long Decode Time (approx. 675 mS)



Extra Long Decode Time (approx. 750 mS)



Save
Settings



Default
to USB



Default
to PS/2



Clear
All Data



Clear
XML
Rules

Button Stay-Down Time

Button Stay-Down Time sets the amount of time (in seconds) that the imager will continue to process the current “decode symbol” event. The imager will behave as if the trigger is being activated for this specified amount of time.

Parameters	ESP Values
[-] Read Cycle	
[-] Default Continuous Event	Idle
Event Delay	0
Read Cycle Timeout	375
Target Time before Decode	25
Button Stay-Down Time	0.200 <input type="text"/> Seconds
Ignore Duplicate Symbol Timeout	0
Quadrus IP Mode	Standard Mode
Imager Resolution	VGA (640 x 480)
Targeting Zone Tolerance	1600
[-] Time before Power-Saving Idle	300000
Extra Time when cable connected	2147483647
[-] Time before power-Saving Sleep	10
Time before Sleep when Cabled	2147483647
Time before Power-Saving Standby Mode	90
Time before Sleep	7200
Continuous Illumination	Off between reads
Auto White Balance	Disabled

Available **Button Stay-Down Time** values are 0.000 to 2147483.750 (in seconds).

Mirroring

Mirroring allows the MS-Q to decode symbols that are reversed. When Mirroring is enabled, all other decode functionality is disabled.

Note: Once the imager has been set to **Mirroring On**, it can only return to its default mode by reading the **Mirroring Off** symbol below.

Mirroring On



M182_01

Mirroring Off (Default)



M181_02

Note: Mirrored symbols can be read on dark or light backgrounds (depending on the current Symbol Background setting. See [Symbol Background](#) on page 7-20.)

Image Transform

In **ESP**, the **Mirroring** feature is part of the **Image Transform** command.

When Image Transform is set to **Standard**, **Mirrored Image** is disabled.

When Image Transform is set to **Mirrored Image**, the MS-Q's optics reverse the captured image before attempting to decode.



M188_02

Save
Settings

M049_03

Default
to USB

M060_03

Default
to PS/2

M071_01

Clear
All Data

M052_01

Clear
XML
Rules

Motion Detection

Motion Detection causes the MS-Q to attempt a decode whenever it senses motion in its field of view.

Motion Detection On



M701_01

Motion Detection Off (Default)



M702_01

Motion Detection by ESP

Motion Detection settings can be refined further using the options in **ESP**.

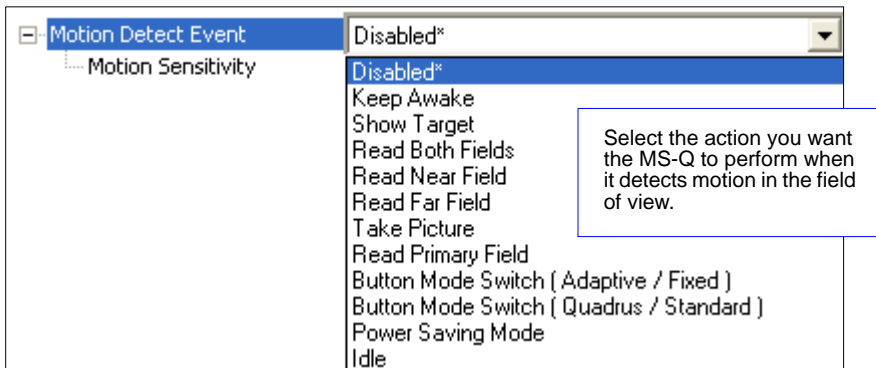

Motion Sensitivity

The MS-Q's sensitivity to motion in the field of view can be configured as shown below.

Note: The lower the number, the greater the sensitivity.



M188_02

Save Settings



M049_03

Default to USB



M060_03

Default to PS/2



M071_01

Clear All Data



M052_01

Clear XML Rules

Auto White Balance

When **Auto White Balance** is enabled, the MS-Q performs an automatic white balance routine, much like a digital camera. Light and dark values are optimized to improve decode performance.

Parameters	ESP Values
[-] Read Cycle	
[-] Default Continuous Event	Idle
Event Delay	0
Read Cycle Timeout	375
Target Time before Decode	25
Button Stay-Down Time	200
Ignore Duplicate Symbol Timeout	0
Quadrus IP Mode	Standard Mode
Imager Resolution	VGA (640 x 480)
Targeting Zone Tolerance	1600
[-] Time before Power-Saving Idle	300000
Extra Time when cable connected	2147483647
[-] Time before power-Saving Sleep	10
Time before Sleep when Cabled	2147483647
Time before Power-Saving Standby Mode	90
Time before Sleep	7200
Continuous Illumination	Off between reads
Auto White Balance	Disabled*
	Disabled*
	Enabled

Symbol Readability Index

The Symbol Readability Index provides a measurement of a specific symbol's readability. It is specific to the MS-Q Imager and should not be confused with a verification quality measurement.

The Symbol Readability Index is a blend of information obtained from the internal operations of the decoding algorithm relating to contrast, symbology construct, error detection, forward error correction (if applicable), and other symbology-specific characteristics.

The Index is a score on a scale of 1 (very poor) to 100 (very readable). Due to the effects of motion, skew, reflection, focus, and ambient light, the Readability Index on the same symbol may vary somewhat from read to read. However, a poor contrast or damaged symbol will score lower than a high contrast undamaged symbol. The Index can be used as a quick check on the reliability of label generation or marking systems. When used in conjunction with a stand and constant ambient light, the Index provides a symbol quality assurance tool and check-point for feedback to an overall symbol or marking quality control system.

The Symbol Readability Index is enabled by reading an XML rule into imager memory.

Enable Symbol Readability Index



The imager will store this XML rule and reset, but will not output a Readability Index value until the **Enable Readability Index Output** symbol is read. When output is enabled, a Symbol Readability Index value will be added to all decoded data output.

Example: 100 (symbol readability),1234567890 (symbol data)

The imager will output the Symbol Readability Index for every decode until the feature is disabled.

Enable Readability Index Output



Disable Readability Index Output



Save Settings



Default to USB



Default to PS/2



Clear All Data



Clear XML Rules

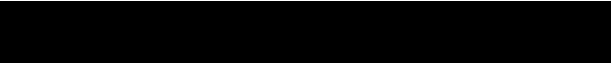

8 Terminal

Contents

- Terminal View..... 8-2
- Find 8-3
- Send 8-4
- Macros..... 8-5
- Terminal Right-Click Menu..... 8-6
- Terminal Dropdown Menu..... 8-7

This section describes the **Terminal** interface and macro functions in **ESP**.

Terminal View

Click the **Terminal** button.



You will see the following view:

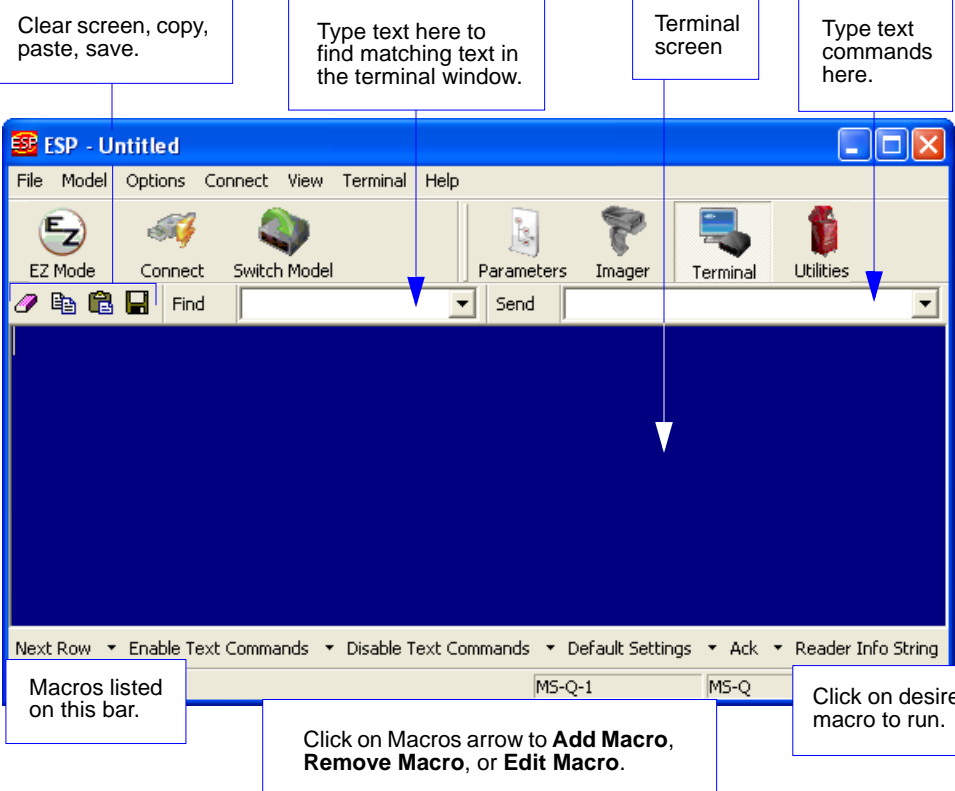

The screenshot shows the ESP software interface with the Terminal view active. The window title is "ESP - Untitled". The menu bar includes File, Model, Options, Connect, View, Terminal, and Help. The toolbar contains icons for EZ Mode, Connect, Switch Model, Parameters, Imager, Terminal, and Utilities. The main area is a large blue terminal screen. Below the terminal screen is a macro bar with a dropdown arrow and the text "Macros listed on this bar." The macro bar shows "MS-Q-1" and "MS-Q".

Callouts:

- Clear screen, copy, paste, save.
- Type text here to find matching text in the terminal window.
- Terminal screen
- Type text commands here.
- Macros listed on this bar.
- Click on Macros arrow to **Add Macro**, **Remove Macro**, or **Edit Macro**.
- Click on desired macro to run.

The Terminal interface allows you to send commands to the imager by using macros, by copying and pasting, or by typing commands in the **Send** text field.

The Terminal view also displays symbol data or information from the imager.

You can also right click on the Terminal screen to bring up a menu of further options.

Find

The **Find** function allows you to enter text strings to be searched for in the terminal window. For example, suppose a series of symbols have been scanned into the terminal view and you want to determine if a particular symbol whose data begins with “ABC” has been read.

1. Type “ABC” into the **Find** box.

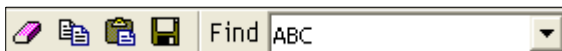

2. Press **Enter**.

The first instance of “ABC” will be highlighted in the terminal window.

3. Click the **Find** button to the left of the text field to locate additional instances of “ABC”.

Send

The **Send** function allows you to enter text commands and then send them to the imager. (See [Text Commands](#) on page 4-24.)

For example, suppose you want to enable the imager's laser target. To enable the target using a text command, you would enter "P%0f3" (the command string that activates the laser target) in the text field and click **Send**.

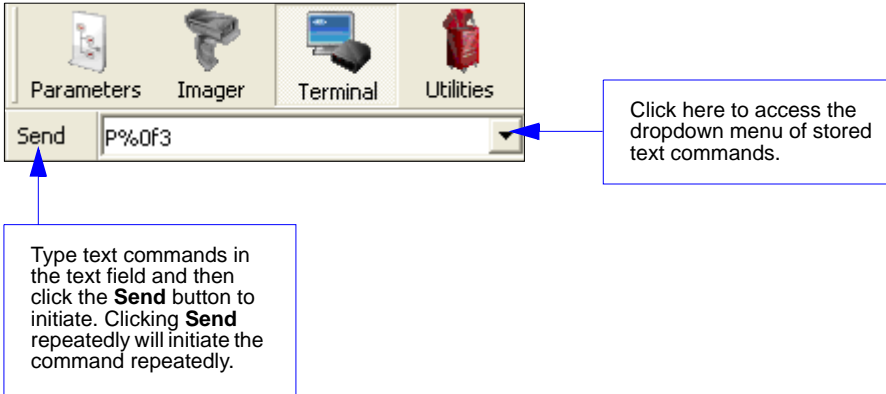

Once text commands are initiated, they are saved in a dropdown menu that can be accessed by clicking the arrow to the right of the text field.

You can also send the current command repeatedly by clicking the **Send** button repeatedly.

Macros

Macros can be stored in a macro selection bar, edited in a separate window, and executed by clicking on the macro name.

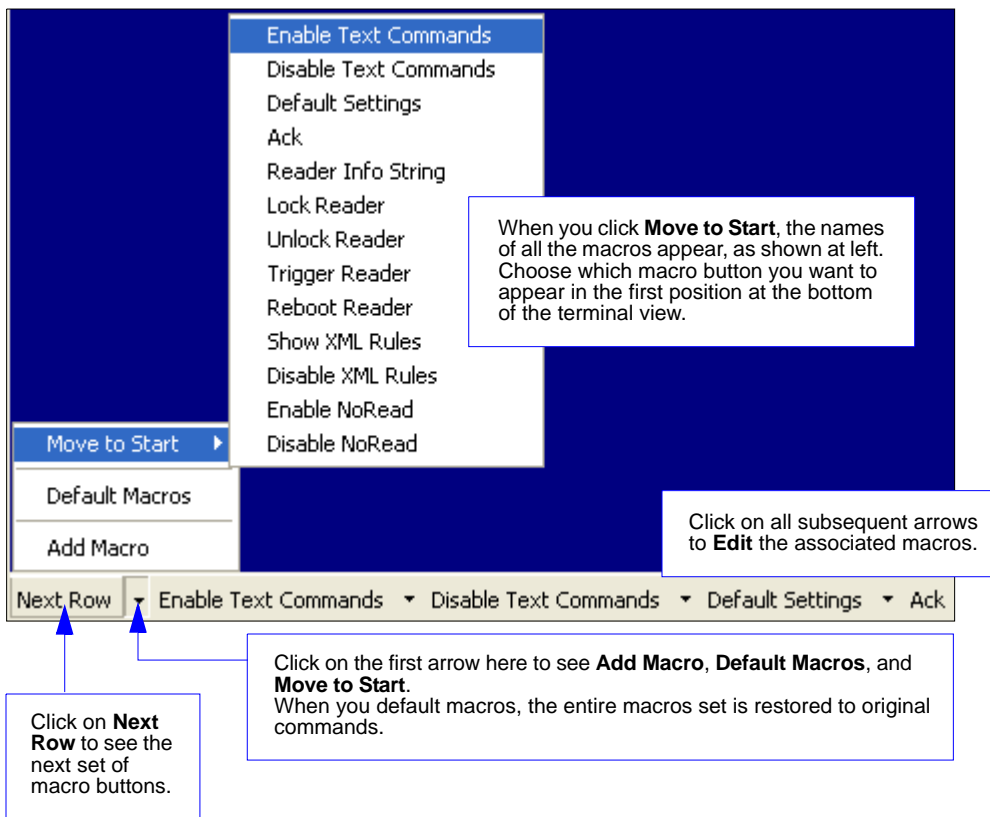

Clicking on a macro button executes the related command. The command is also sent to the imager at the same time it is displayed.

Editing a Macro

When you click the arrow next to a any macro and select **Edit**, the following dialog appears:

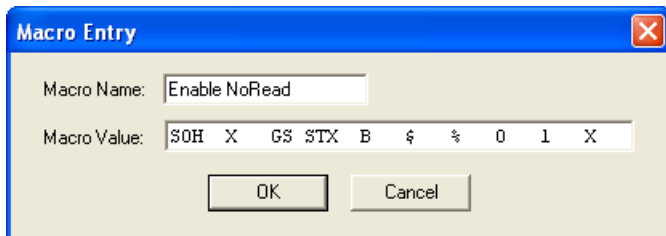

You can edit an existing macro or type in the **Macro Name** text field and define it in the **Macro Value** text field.

Terminal Right-Click Menu

Right click in the terminal window to display the following menu:

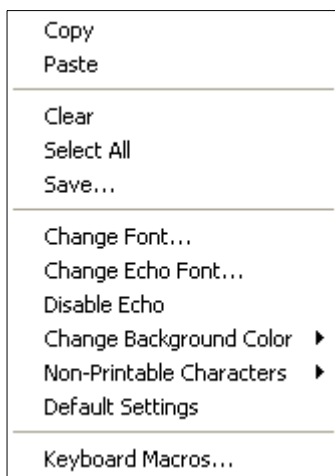

- **Copy** selected text to clipboard.
- **Paste** from terminal or other text.
- **Clear** all text in terminal window.
- **Select All** text in the terminal window.
- **Save...** incoming and outgoing data into a text file.
- **Change Font...** of data received from the imager.
- **Change Echo Font...** to change the appearance of user-entered data.
- **Disable Echo** to hide user-entered data.
- **Change Background Color** of the terminal window.
- **Non-Printable Characters** can be shown or hidden in the terminal view in **Standard** or **Enhanced** format.
- **Default Settings** to return all of the above to original settings.
- **Keyboard Macros** brings up the **Function Keys** dialog, which allows you to create customized macro functions.

Function Keys

The **Function Keys** dialog allows you to assign commands to specific function keys on a standard keyboard. Note that the **F1** key is reserved for opening **ESP Help**, and the **F3** key is reserved for the **Find Next** function.

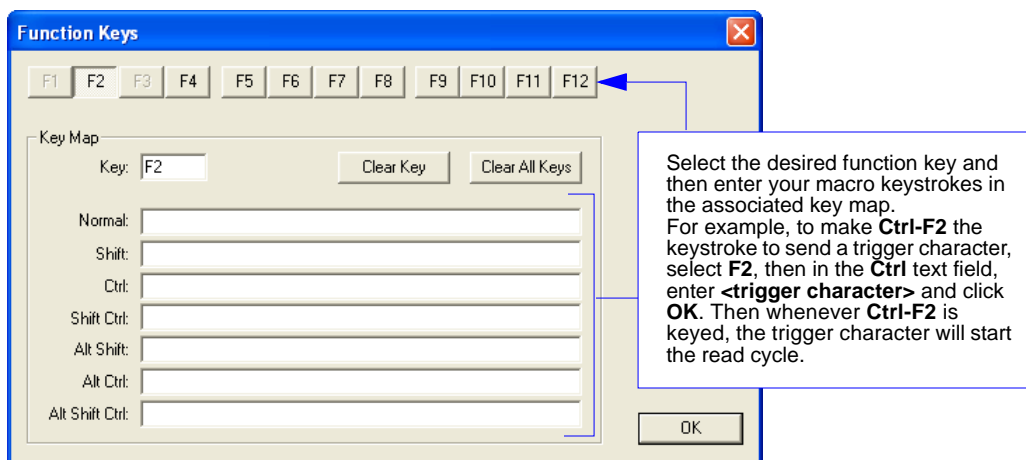

Note: This feature is also available from the **Terminal Dropdown Menu** and the **Terminal** tab of the **Preferences** dialog.

Terminal Dropdown Menu

The terminal dropdown menu allows you to capture and save current text, and it also includes the functions defined for the [Terminal Right-Click Menu](#).

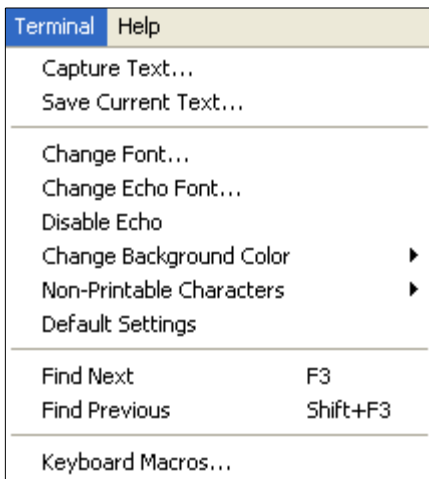

- **Capture Text...** lets you append data in real time to a text file of your choice. While in operation, the text file cannot be opened. You can select **Pause** to interrupt the capture flow or **Stop** to end the flow and open the file.
- **Save Current Text...** saves all text in the terminal window to a text file of your choice.
- **Find Next** locates the next instance of the specified data string in the terminal. This function can also be activated by pressing **F3**.
- **Find Previous** locates the most recently occurring instance of the specified data string in the terminal.
- **Keyboard Macros** brings up the **Function Keys** dialog, which allows you to create customized macro functions.

9 Utilities

Contents

Image Upload.....	9-2
Device Control.....	9-3
Differences from Default	9-4
Firmware	9-5
Bluetooth	9-7
Advanced	9-8

This chapter explains **ESP's Utilities** features. These include **Image Upload**, which allows you to capture images using the MS-Q; **Device Control**, an interface that lets you perform major operations with one click; **Differences from Default**, which shows all currently enabled MS-Q settings that are not default settings; **Firmware**, where you can update your imager's firmware; **Bluetooth**, which can produce a "Quick Connect" symbol from alphanumeric text input; and **Advanced**, which allows you to collect batch files for customized imager configuration and optimization.

Image Upload

ESP's **Image Upload** feature allows you to collect and save image captures.

The screenshot shows the 'Image Upload' software interface. It features several control panels and image display windows. Callout boxes provide instructions for various elements:

- Image Quality:** A panel with radio buttons for 'Low', 'Medium' (selected), 'High', and 'BMP'.
- Image to Upload:** A panel with radio buttons for 'Far Field' and 'Near Field' (selected), and a resolution dropdown menu set to 'SXGA'.
- Select Trigger to Take Picture:** A dropdown menu set to 'Right Button' and a 'Start' button.
- Far Field Window:** Displays a grayscale image of a textured surface with a measurement of '16.76 mm'. Below it is a 'Save Image...' button.
- Near Field Window:** Displays a grayscale image of a textured surface with a measurement of '4.95 mm'. Below it is a 'Save Image...' button and the text 'Double click image to enlarge'.

Callout boxes contain the following text:

- Choose desired JPEG image resolution, or select Bitmap (BMP) format.
- Select your depth of field and field of view (SXGA-1280 x 1024) (VGA available for Rev 5 hardware or earlier).
- Select the trigger you want to use to capture the image, then click the **Start** button to begin the image capture process.
- Image captures are displayed in the **Far Field** and **Near Field** windows, depending on which field is enabled (Far, Near, or Both).

Device Control

This feature allows you to clear data stored in the imager's memory, to default the imager, to deactivate or clear XML rules, to upload or delete stored errors, to reboot the imager, and to delete stored results.

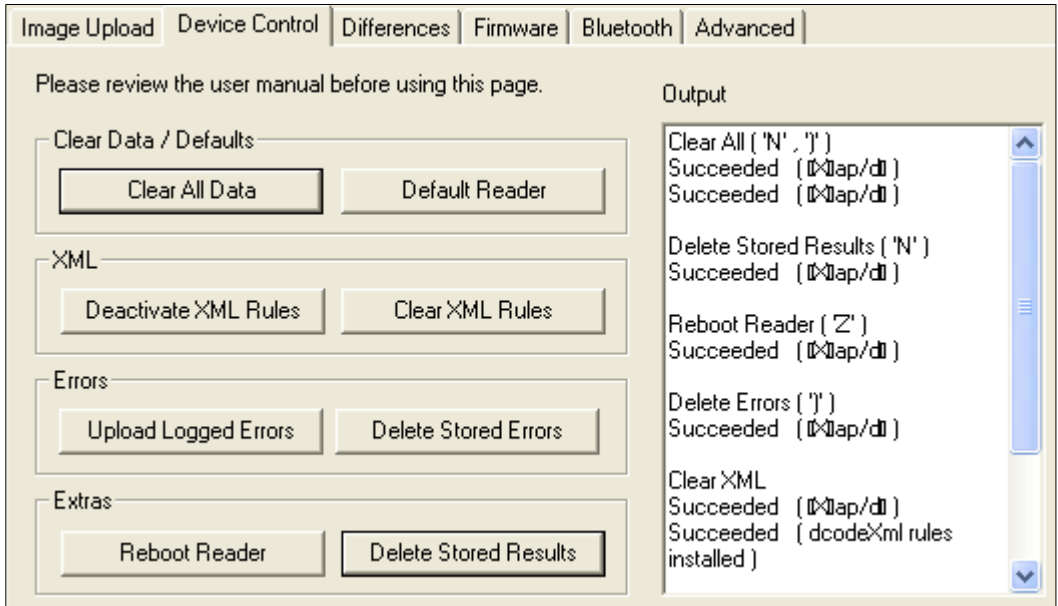

- **Clear All Data** removes decoded symbol data and commands in the imager's memory.
- **Default Reader** returns the imager to its default state, without any optimization or configuration.
- **Deactivate XML Rules** turns off, but does not erase, preambles, postambles, and XML commands.
- **Clear XML Rules** removes preambles, postambles, and other XML commands.
- **Upload Logged Errors** allows you to look at stored error reports.
- **Delete Stored Errors** erases all logged errors whether you have looked at them or not.
- **Reboot Reader** refreshes the imager's memory and functionality, returning it to the most recent configuration you have saved.
- **Delete Stored Results** erases logged data.

Differences from Default

Clicking the **Differences from Default** button will cause **ESP** to check all stored configuration settings and compare them to default settings. All settings that are different from default will appear in the left column (shown below), and descriptions of those settings will appear in the right column.

Click this button for a list of **ESP** configuration settings that are different from default settings.

Click **Generate Barcode** to bring up the **Bar Code Configuration** dialog. Then create symbols containing the configuration commands of your choice.

Command	Description
↑↑↑↑P05	Communications Mode (USB Native (HID))
↑↑↑↑P0&5	Volume (5)

Send configuration settings to the reader without saving by clicking **Send to Reader**.

Click **Save As** to save the report as plain text or a tab-delimited text file.

Send configuration settings to the reader and save in ESP by clicking **Send and Save**.

- To create a symbol containing any of the command settings in the table, click **Generate Barcode**. This will bring up the **Bar Code Configuration** dialog.
- To save the **Differences from Default** report, either as plain text or as a tab-delimited text file, click **Save As**.
- Click **Send and Save** to send the settings to the reader and save them, or **Send to Reader** to send the settings without saving them.

Firmware

The **Firmware** view in **ESP Utilities** is a simple way to update and verify your imager's firmware and to update batch files.

Choose **App Code** from the **Firmware Update** dropdown menu and click **Start** to install new firmware in the MS-Q.

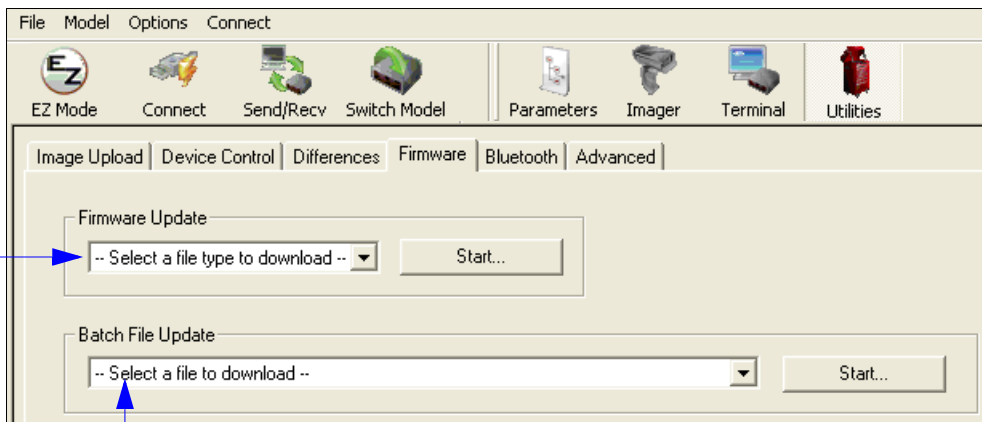

Use this dropdown menu to locate batch files in the host computer's file directory. Download the needed files directly to the imager by clicking the **Start** button.

The **Firmware Verification** tool sends a direct query to the imager for its Application Code Version, Firmware Version, Boot Code Version, and Radio Version.

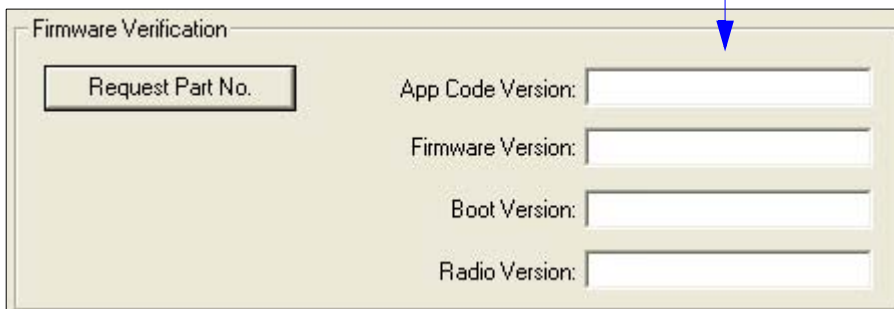

Imager ID

Another way to query the imager for its identifying information is by reading the following symbol:



Imager ID

M153_01

The host's text program will output a data string containing the imager's identifying information in the following format:

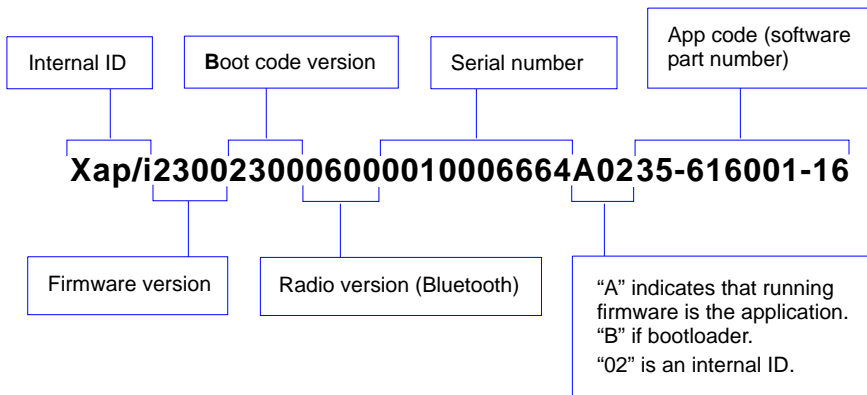

Save Settings

M188_02



Default to USB

M049_03



Default to PS/2

M060_03



Clear All Data

M071_01



Clear XML Rules

M052_01

Bluetooth

The **Bluetooth** view in **Utilities** features a text field in which you can enter your Bluetooth modem's alphanumeric **Quick Connect Code**. When you are finished entering this code, the small window below the text field displays a Data Matrix symbol that you can print and use thereafter to connect instantly.

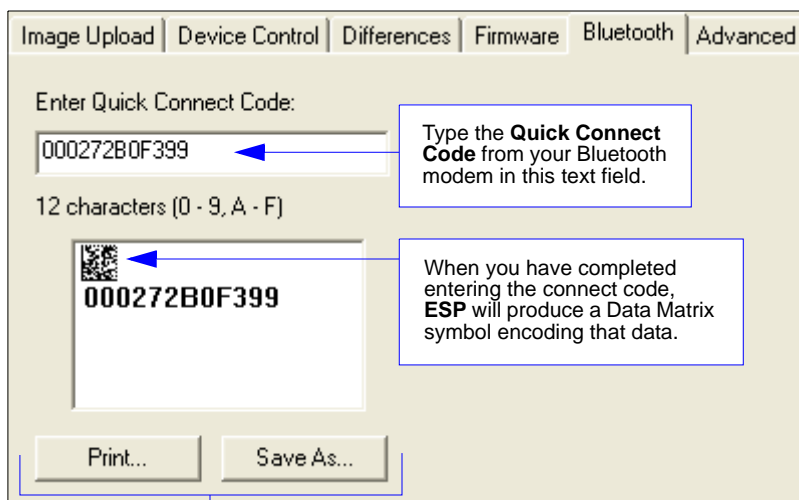

Type the **Quick Connect Code** from your Bluetooth modem in this text field.

When you have completed entering the connect code, **ESP** will produce a Data Matrix symbol encoding that data.

Print and save the symbol for future use.



Save Settings



Default to USB



Default to PS/2



Clear All Data



Clear XML Rules

Advanced

The **Advanced** tab in **Utilities** features an archive of all batch files containing imager configuration commands. Each batch file's extension is .crb, and each file contains the fundamental code for programming the imager. Notice that the names of the batch files correspond with the numbers beneath all the Data Matrix configuration symbols in this manual.

This tool allows you to use the batch file data to create your own symbols, or to collect only the files that you use frequently to configure the imager for your application.

The screenshot shows the 'Advanced' tab in the Utilities application. It features three main sections: 'Batch File Archive', 'Batch File Collection', and 'Batch File Creator'. The 'Batch File Archive' section contains a list of batch files with columns for 'Batch File' and 'Description'. The 'Batch File Collection' section contains a similar list. The 'Batch File Creator' section contains two buttons: 'Download Collection' and 'Save Collection As...'. Callouts provide instructions on how to use these features.

Batch File Archive

Batch File	Description
M157_01	Handle Trigger - R...
M158_02	Handle Trigger - U...
M159_02	Prefix - Comma
M160_04	Suffix - Comma
M161_04	Suffix - Enter
M162_01	Prefix Erase None
M163_01	Suffix - Erase / No...
M164_02	Prefix - Space
M165_04	Suffix - Space
M166_01	Prefix - Tab - Keyb...
M167_04	Suffix - Tab - Keyb...
M168_04	Suffix - Carriage R...
M169_04	Suffix - Line Feed ...
M170_04	Suffix - Carriage R...
M171_01	Custom Keyboard
M172_01	US Keyboard Map...
M173_01	Universal Keyboar...
M174_01	Control LED's Sep...
M175_01	Control LED's Sep...
M176_01	Left Trigger - Rea...
M177_01	Left Trigger - Rea...
M178_01	Left Trigger - Rea...
M179_01	Left Trigger Take ...
M180_02	Left Trigger - Uplo...
M181_01	Mirroring - Off
M182_01	Mirroring - On
M183_01	Right Trigger - Re...
M185_01	Right Trigger - Re...
M186_01	Right Trigger Tak...
M187_02	Right Trigger - Up...
M189_01	Set Targeting Zon...
M190_01	Set Targeting Zon...
M191_01	Set Targeting Zon...
M192_01	Set Targeting Zon...
M193_01	Set Targeting Zon...
M194_01	Set Targeting Zon...
M195_01	Set Targeting Zon...
M196_01	Set Targeting Zon...
M197_01	Reader Text Com...
M198_01	Reader Text Com...
M199_01	Time Stamp Settin...
M200_01	Time Stamp Settin...
M201_02	Enable SXGA - 12...

Batch File Collection

Batch File	Description
M184_01	Right Trigger - Read ...
M188_02	Save Settings

Batch File Creator

Download Collection

Save Collection As...

The **Download Collection** and **Save Collection As...** buttons allow you to acquire the entire contents of the batch file archive and save the files in a location of your choice.

Scroll through the list of batch files in the archive and choose the ones you need. Move them to the collection window using the **Add** arrow. Files can also be transferred by clicking and dragging.

The single **Remove** arrow functions in the same way as the **Add** arrow, except that it transfers files back to the batch archive. The double **Remove** arrow allows you to transfer all files simultaneously.

■ *10 Unique Item Identifiers*

Contents

UII Overview	10-2
Non-UII Characters.....	10-3
UII Mode Features.....	10-4
Error Messaging	10-6
Valid Formats	10-8

This section explains the structure and purpose of Unique Item Identifiers (UIIs) and how to configure the MS-Q Imager to read them.

UII Overview

The Department of Defense (DoD) now requires Unique Item Identifiers (UIIs) for all products sold to the DoD by private vendors. A UII can be thought of as a Social Security number for each part. The UII must be encoded in a Data Matrix ECC 200 symbol that conforms to the data structure defined in the DoD’s “Guide for Uniquely Identifying Items.”

UII Elements

UIIs come in two forms, called **Construct 1** and **Construct 2**. The following is an example of Construct 2. Construct 1 is identical, except that it doesn’t include a part number. Construct 2 is composed of three basic elements:

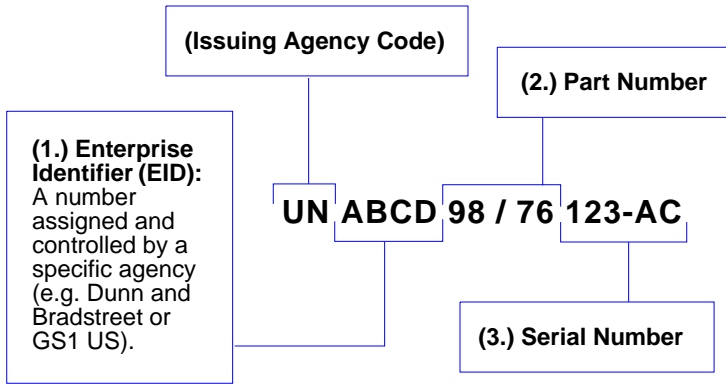

Encoding a UII

The information in a Data Matrix UII also includes a compliance indicator, data qualifiers, and data element separators. None of these elements are part of the final UII. When **UII-Only Mode** is enabled in the imager, the characters that are not part of the UII are removed from the decoded symbol data. Only characters that make up the UII are passed on to the host computer. Otherwise, the symbol is rejected.

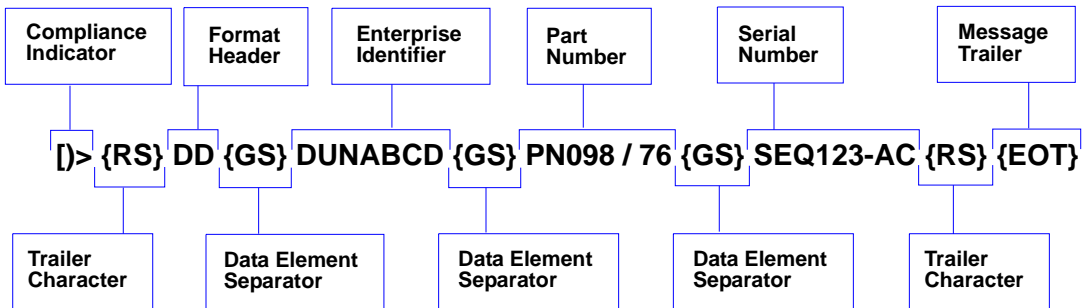

Non-UII Characters

The table below identifies and describes all characters in a UII message stream that are not part of the final UII sent to the host.

Non-UII Characters in a UII Message Stream

<i>Compliance Indicator</i>	Identifies to the imager that the symbol contains a UII.
<i>Format Header</i>	Describes the type of data qualifier used. These qualifiers include AI (format 05), DI (format 06), and TEI (format DD).
<i>Trailer Character</i>	An ASCII character that separates the compliance indicator from the format header information, and also appears at the end of the message stream.
<i>Data Element Separator</i>	An ASCII character used to separate data fields.
<i>Message Trailer</i>	Identifies the end of the message within the data stream.
<i>Data Qualifier</i>	Defines each data element placed in the UII message stream.

When a message stream in any of the three available formats is read by the imager, non-UII characters are omitted and the UII is sent to the host.

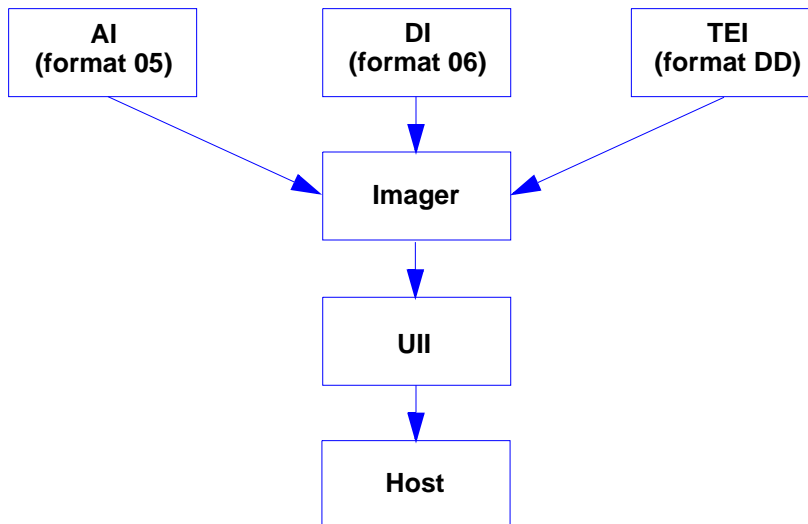

UII Mode Features

<i>UII-Only Enabled</i>	Allows the imager to read <i>only</i> UII message streams encoded in ECC 200 Data Matrix symbols and to send the UII output to the host computer. The imager will not read any other symbol data when UII-Only is enabled.
<i>UII-Only Enabled with Error Messaging</i>	Allows the imager to read <i>only</i> UII message streams encoded in ECC 200 Data Matrix symbols and to send the UII output to the host computer. In addition, the imager will send an error message to the host if the UII message stream is invalid.
<i>UII Enabled with Pass Through</i>	Allows both UII-encoded symbols and non-UII symbols to be decoded and sent to the host.
<i>UII Enabled with Error Messaging and Pass Through</i>	Allows the imager to decode UII symbols and non-UII symbols, and to provide error messages if the UII message stream is invalid.

UII Mode Settings

The following symbols control UII functions:



Q014_01

UII-Only Enabled



Q015_01

UII-Only Enabled with Error Messaging



Q016_01

UII Enabled with Pass Through



Q017_01

UII Enabled with Error Messaging and Pass Through



Q018_01

UII Disabled (Default)



M188_02

Save Settings



M049_03

Default to USB



M060_03

Default to PS/2



M071_01

Clear All Data



M052_01

Clear XML Rules

UII Mode Settings by ESP

Each of the **UII Mode Settings** can also be enabled in **ESP's I/O Parameters** tree control or graphic interface.

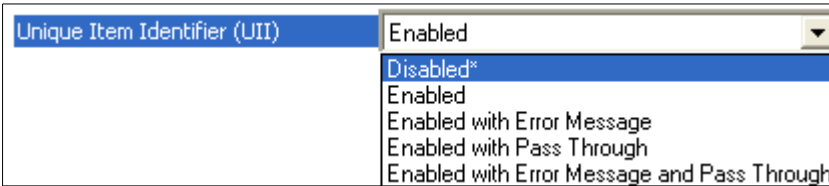

UII-Only Enabled

UII (Unique Item Identifier)

Enable Append Error Message

Pass Through

UII-Only Enabled with Error Messaging

UII (Unique Item Identifier)

Enable Append Error Message

Pass Through

UII Disabled

UII (Unique Item Identifier)

Enable Append Error Message

Pass Through

UII Enabled with Pass Through

UII (Unique Item Identifier)

Enable Append Error Message

Pass Through

UII Enabled with Error Messaging and Pass Through

UII (Unique Item Identifier)

Enable Append Error Message

Pass Through

Error Messaging

This feature is used to validate that UII message streams are in the correct format. When Error Messaging is enabled, the imager sends a message to the host indicating an error every time a bad symbol is read. The table below shows examples of error messages.

Examples of Error Messages

<i>Invalid Format Header</i>	<pre>]>{RS}15{GS}800406141411A0B9C3D6{RS}{EOT}</pre> <p>Error message: "Invalid UII Format Header"</p>	
<i>Invalid AI</i>	<pre>(01 + 21)]>{RS}05{GS}0100061414199999{GS}311A0B9C3D6{RS}{EOT}</pre> <p>Error message: "Invalid AI"</p>	
<i>Invalid DI</i>	<pre>(UN + 12V + 1P + S)]>{RS}06{GS}12X077991289{GS}1P4202435{GS}S10936{RS}{EOT}</pre> <p>Error message: "Invalid DI"</p>	
<i>Invalid TEI</i>	<pre>(D + CAG + SER)]>{RS}DD{GS}CAX987654{GS}SERMKLJHUIYD{RS}{EOT}</pre> <p>Error message: "Invalid TEI"</p>	
<i>Space in Data Qualifier</i>	<p style="text-align: center;">↓</p> <pre>]>{RS}05{GS}8 0040614 1411 A0 B9 C3D6{RS}{EOT}</pre> <p>Error message: "Invalid AI (or DI or TEI depending on format in use)"</p>	
<i>Lower Case Characters</i>	<pre>]>{RS}05{GS}800406141411a0B9C3d6{RS}{EOT}</pre> <p>Error message: "Invalid Characters in Data"</p>	



Save Settings

M188_02



Default to USB

M049_03



Default to PS/2

M060_03



Clear All Data

M071_01









Clear XML Rules

M052_01

Error Messaging

Examples of Error Messages (cont.)

<p><i>Invalid Characters</i></p>	<p>[]>{RS}05{GS}800406141411#0B9C3D6{RS}{EOT} Error message: "Invalid Characters in Data"</p>	
<p><i>UII Too Long</i></p>	<p>(Character limit:78) >[]>{RS}05{GS}80021234567891123456789212345678931234567894123456789512345678961234567897123456789{RS}{EOT} Error message: "UII Too Long"</p>	
<p><i>Part Number Too Long</i></p>	<p>(Character limit: 32) >[]>{RS}DD{GS}DUNABCD{GS}PNO1234567891123456789212345678931234{GS}SEQ123-AC{RS}{EOT} Error message: "UII Part Number Too Long"</p>	
<p><i>Serial Number Too Long</i></p>	<p>(Character limit: 30) >[]>{RS}DD{GS}DUNABCD{GS}PNO098/76{GS}SEQ1234567891123456789212345678931{RS}{EOT} Error message: "UII Serial Number Too Long"</p>	
<p><i>EID Too Long</i></p>	<p>(Character limit: 13) >[]>{RS}DD{GS}DUN12345678911234211{GS}PNO98/76{GS}SEQ123-AC{RS}{EOT} Error message: "UII EID Too Long"</p>	
<p><i>Invalid Compliance Indicator</i></p>	<p>[D]>{RS}05{GS}800406141411A0B9C3D6{RS}{EOT} Error message: "Invalid UII Compliance Indicator" The following symbol <i>will read</i> in UII with Pass Through mode, because the invalid compliance indicator suggests that the encoded characters form a non-UII message stream.</p>	



Save Settings



Default to USB



Default to PS/2



Clear All Data



Clear XML Rules

Valid Formats

The table below shows examples of correctly encoded UII message streams and the decoded UII output.

Examples of Valid UII Message Streams and UII Output

<i>AI (Format 05)</i>	<p>Encoded message stream: []>(RS)05(GS)0100061414199999(GS)211A0B9C3D6(RS){EOT}</p> <p>Decoded UII output: 000614141999991A0B9C3D6</p>	
<i>DI (Format 06)</i>	<p>Encoded message stream: []>(RS)06(GS)18SOCVA5674A36458(RS){EOT}</p> <p>Decoded UII output: DOCVA5674A36458</p>	
<i>TEI (Format DD)</i>	<p>Encoded message stream: []>(RS)DD(GS)CAG987654(GS)SERMKJHUIYD(RS){EOT}</p> <p>Decoded UII output: D987654MKLJHUIYD</p>	



Save Settings

M188_02



Default to USB

M049_03



Default to PS/2

M060_03



Clear All Data

M071_01



Clear XML Rules

M052_01

Appendices

- Appendix A General Specifications A-2
- Appendix B Electrical Specifications A-4
- Appendix C Configuration Symbols A-7
- Appendix D Configuration Symbol Reference List A-41
- Appendix E Hardware Default and Manual Battery Recharge A-58
- Appendix F MS-Q Quadrus Secure with Image Lock A-61
- Appendix G MS-Q Protective Jacket A-62
- Appendix H MS-Q Battery Charger A-63
- Appendix I MS-Q Bluetooth Modem A-65
- Appendix J MS-Q Maintenance A-68

Appendix A — General Specifications

Mechanical

Imager	
Height:	1.3" (33 mm)
Width:	1.8" (46 mm)
Depth:	4.3" (109 mm)
Weight:	4 oz. (113 g) (not including cable)
Cable:	6' (1.8 m)

Handle Weight	
Cabled:	4.0 oz. (113 g)
Cabled w/ Imager:	7.2 oz. (204 g)
With 1950 mAh Battery (Not available with Rev 6 hardware):	4.8 oz. (136 g)
With 1950 mAh Batt./Imager (Not available with Rev 6 hardware):	8 oz. (227 g)
With 3900 mAh Battery:	6.4 oz. (181 g)
With 3900 mAh Batt./Imager:	9.6 oz. (272 g)

Environmental

Operating temperature: 0° to 50°C (32° to 122°F)

Storage temperature: -20° to 60°C (-4° to 140°F)

Humidity: 5 to 90% (non-condensing)

CE Standards

Immunity: EN 55024

ESD: EN 61000-4-2

Radiated RF: EN 61000-4-3, ENV 50204, EFT EN 61000-4-4

Conducted RF Immunity: EN61000-4-6

Emissions: EN55022, Class B Radiated, Class B Conducted

Light Collection Options

Sensor: CMOS, progressive scan, 1.33 MP (1024 x 1280). 256 gray scale

Standard Resolution Field of View:

Near: 21.5° horizontal by 16.2° vertical

Far: 22.9° horizontal by 11.6° vertical

Standard Resolution Focal Point:

Near: 4" (101.6 mm)

Far: 9" (228.6 mm)

High Resolution Focal Point:

Near: 2.75" (70 mm)

Far: 4.5" (115 mm)

Sensor Array:

Near Field: 1024 by 640 (Default)

Far Field: 1024 by 640 (Default)

Communication Protocols

Standard Interface: USB

Optional Interface: RS-232, Bluetooth Class 1 Radio at 328' (100m), PS/2

Image Output Options

Format: JPEG, BMP, Image Lock

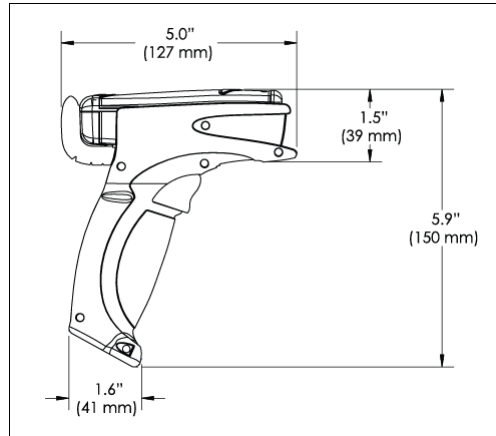

MS-Q Imager Dimensions
(Shown with H2 Handle Option)

Read Parameters

Pitch: ±60° (front to back); Skew: ±60°; Tilt: ±360°

Focal Range: 1 to 20" (25 to 508 mm)

Rotational Tolerance: ±180°

Print contrast Resolution: 25% (1D symbols); 35% (PDF417); absolute dark/light reflectance differential, measure at 650 nm.

Target Beam: Visible Laser Diode at 630 nm. Class 2

Ambient Light Immunity: Sunlight: Up to 9000 ft. candles, 96,890 lux

Shock: Withstands 100+ drops of 6.5' (2 meters) to concrete

Indicators

LEDs: Memory status, Battery power, Successful decode, connection status

Programmable Indicators: Beep or Vibrate options indicate imager operation and connection status

Safety Certifications

FCC, CE, RoHS/WEEE



ISO 9001:2000 Certification No. 06-1080

Issued by TÜV USA

Copyright ©2009

Microscan Systems, Inc.

All rights reserved. Specifications subject to change. Product specifications are given for typical performance at 25°C (77°F) using grade A labels. Performance characteristics may vary at high temperatures or other environmental extremes. Warranty—One year limited warranty on parts and labor. Extended warranty available.

FIS Options

MS-Q Quadrus, High Resolution, USB, H2	FIS-6100-0030G
MS-Q Quadrus, High Resolution, Batch/Battery, BH1	FIS-6100-0031G
MS-Q Quadrus, High Resolution, Batch/Battery, BH2	FIS-6100-0032G
MS-Q Quadrus, High Resolution, Bluetooth, BH1	FIS-6100-0033G
MS-Q Quadrus, High Resolution, Bluetooth, BH2	FIS-6100-0034G
MS-Q Quadrus, Standard Resolution, USB, H2	FIS-6100-0035G
MS-Q Quadrus, Standard Resolution, Batch/Battery, BH1	FIS-6100-0036G
MS-Q Quadrus, Standard Resolution, Batch/Battery, BH2	FIS-6100-0037G
MS-Q Quadrus, Standard Resolution, Bluetooth, BH1	FIS-6100-0038G
MS-Q Quadrus, Standard Resolution, Bluetooth, BH2	FIS-6100-0039G
MS-Q Quadrus, High Resolution, PS/2	FIS-6100-0040G
MS-Q Quadrus, Standard Resolution, PS/2	FIS-6100-0041G
MS-Q Quadrus SW, Standard Resolution, Bluetooth (Telec approved), BH1	FIS-6100-0042G
MS-Q Quadrus SW, Standard Resolution, Bluetooth (Telec approved), BH2	FIS-6100-0043G
MS-Q Quadrus SW, High Resolution, Bluetooth (Telec approved), BH1	FIS-6100-0044G
MS-Q Quadrus SW, High Resolution, Bluetooth (Telec approved), BH2	FIS-6100-0045G
MS-Q Quadrus SW, Standard Resolution, Image Lock, H2	FIS-6100-0046G
MS-Q Quadrus, High Resolution, USB, H2 (Rev 6 Hardware)	FIS-6100-0047G
MS-Q Quadrus, High Resolution, Batch/Battery (Rev 6 Hardware)	FIS-6100-0048G
MS-Q Quadrus, High Resolution, PS/2 (Rev 6 Hardware)	FIS-6100-0049G
MS-Q Quadrus, High Resolution, Bluetooth (Rev 6 Hardware)	FIS-6100-0050G
MS-Q Quadrus, Standard Resolution, USB, H2 (Rev 6 Hardware)	FIS-6100-0051G
MS-Q Quadrus, Standard Resolution, Batch/Battery (Rev 6 Hardware)	FIS-6100-0052G
MS-Q Quadrus SW, Standard Resolution, Image Lock, H2 (Rev 6 Hardware)	FIS-6100-0053G
MS-Q Quadrus, Standard Resolution, Bluetooth (Rev 6 Hardware)	FIS-6100-0054G
MS-Q Basic, Standard Resolution, USB, H2	FIS-6150-0020G
MS-Q Basic, Standard Resolution, Batch/Battery, BH1	FIS-6150-0021G
MS-Q Basic, Standard Resolution, Batch/Battery, BH2	FIS-6150-0022G
MS-Q Basic, Standard Resolution, Bluetooth, BH1	FIS-6150-0023G
MS-Q Basic, Standard Resolution, Bluetooth, BH2	FIS-6150-0024G
MS-Q Basic, Standard Resolution, PS/2	FIS-6150-0025G
MS-Q Basic, Standard Resolution, Bluetooth (Telec approved), BH1	FIS-6150-0026G
MS-Q Basic, Standard Resolution, Bluetooth (Telec approved), BH2	FIS-6150-0027G
MS-Q Basic, Standard Resolution, USB, H2 (Rev 6 Hardware)	FIS-6150-0028G
MS-Q Basic, Standard Resolution, Batch/Battery (Rev 6 Hardware)	FIS-6150-0029G
MS-Q Basic, Standard Resolution, PS/2 (Rev 6 Hardware)	FIS-6150-0030G
MS-Q Basic, Standard Resolution, Bluetooth (Rev 6 Hardware)	FIS-6150-0031G

LightRay Optics FIS Options

MS-Q Quadrus, High Resolution, USB (PS/2, RS-232), LightRay 100	FIS-6100-1011G
MS-Q Quadrus, High Resolution, Batch/Battery, LightRay 100	FIS-6100-1012G
MS-Q Quadrus, High Resolution, Bluetooth, LightRay 100	FIS-6100-1013G
MS-Q Quadrus, Standard Resolution, USB (PS/2, RS-232), LightRay 110	FIS-6100-1014G
MS-Q Quadrus, Standard Resolution, Batch/Battery, LightRay 110	FIS-6100-1015G
MS-Q Quadrus, Standard Resolution, Bluetooth, LightRay 110	FIS-6100-1016G
MS-Q Quadrus, High Resolution, USB (PS/2, RS-232), LightRay 100 (Rev 6 Hardware)	FIS-6100-1021G
MS-Q Quadrus, High Resolution, Bluetooth, LightRay 100 (Rev 6 Hardware)	FIS-6100-1022G
MS-Q Quadrus, Standard Resolution, USB (PS/2, RS-232), LightRay 110 (Rev 6 Hardware)	FIS-6100-1023G
MS-Q Quadrus, Standard Resolution, Batch/Battery, LightRay 110 (Rev 6 Hardware)	FIS-6100-1024G
MS-Q Quadrus, High Resolution, USB (PS/2, RS-232), LightRay 205	FIS-6100-2011G
MS-Q Quadrus, High Resolution, Batch/Battery, LightRay 205	FIS-6100-2012G
MS-Q Quadrus, High Resolution, Bluetooth, LightRay 205	FIS-6100-2013G
MS-Q Quadrus, Standard Resolution, USB (PS/2, RS-232), LightRay 215	FIS-6100-2014G
MS-Q Quadrus, Standard Resolution, Batch/Battery, LightRay 215	FIS-6100-2015G
MS-Q Quadrus, Standard Resolution, Bluetooth, LightRay 215	FIS-6100-2016G
MS-Q Quadrus, High Resolution, USB (PS/2, RS-232), LightRay 205 (Rev 6 Hardware)	FIS-6100-2021G
MS-Q Quadrus, High Resolution, Batch/Battery, LightRay 205 (Rev 6 Hardware)	FIS-6100-2022G
MS-Q Quadrus, High Resolution, Bluetooth, LightRay 205 (Rev 6 Hardware)	FIS-6100-2023G

Appendix B — Electrical Specifications

Power Requirements: 5 VDC (mA)

Typical: 140; Peak: 310, Sleep: 3

Bluetooth Radio at 295' (90m) (mA):

Typical: 280, Peak: 350, Idle: 96, Sleep: 3

Bluetooth Radio at 33' (90m) (mA):

Typical: 260, Peak: 350, Idle: 96, Sleep: 3

Life of 1950 mAH Battery with Radio: Will support 4,000 read/transmits per charge, including 8 hours of standby interval. (Rev 5 hardware only.)

Life of 3900 mAH Battery with Radio: Will support 8,000 read/transmits per charge, including 16 hours of standby interval.

Batch Memory: 3.8MB available for user data (file system allocates 500 bytes at a time).

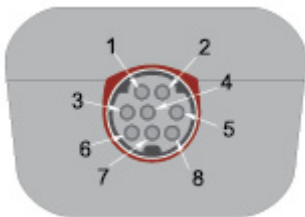

PIN 1	VIN- Input Voltage to the voltage regulators/battery charging IC
PIN 2	RS-232_TX - RS-232 level serial transmit signal
PIN 3	RS-232_RX - RS-232 level serial receive signal
PIN 4	PS/2_DATA_UART_RX_USB_DP - PS/2 clk to host/ UART transmit signal/ USB Data plus signal
PIN 5	PS/2_DATA_UART_RX_USB_DM - PS/2 data to host or keyboard/ UART receive signal/ USB Data minus signal
PIN 6	PS/2_CLK_KB - PS/2 clock signal to the keyboard
PIN 7	~TRIG - trigger from the handle
PIN 8	GND - signal ground
Shield	Shield Ground

USB Cable Pinouts

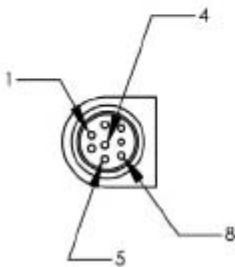
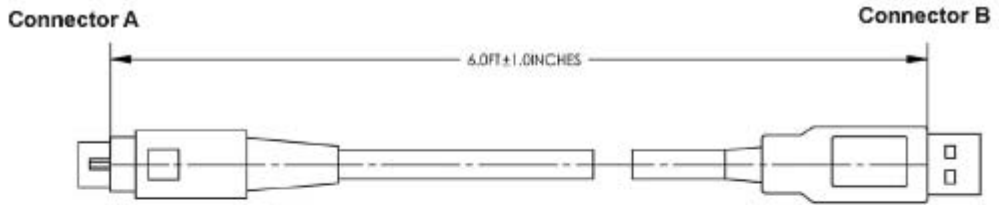

WIRING TABLE:

CONN A	NAME	WIRE	COLOR	CONN B
1	V+	24AWG	RED	1
2	NC			
3	NC			
4	D+	28AWG	GREEN (TWISTED)	3
5	D-	28AWG	WHITE (TWISTED)	2
6	NC			
7	NC			
8	GND	24AWG	BLACK	4
SHELL	--	DRAIN	BARE	SHELL

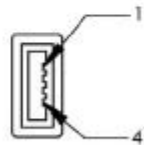

RS-232 Cable Pinouts

Connector B

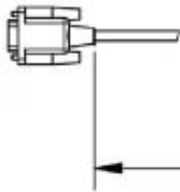

Connector A

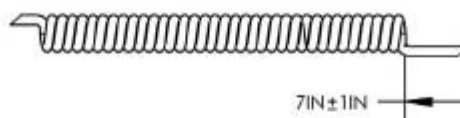
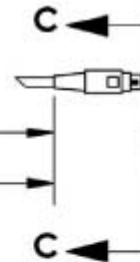

Connector B

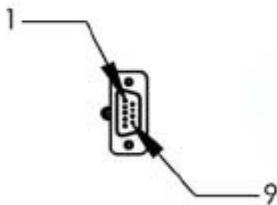

Connector C

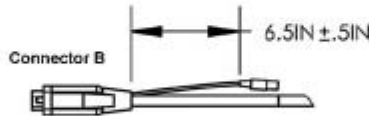

- Center Pin OD 2.0 mm, Length 8.5 mm
- Mating Plug OD: 5.5 mm

Input: + 5V Min 500 mA



Connector A

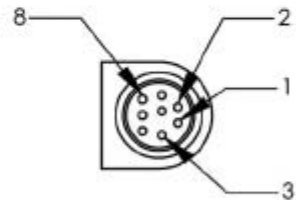







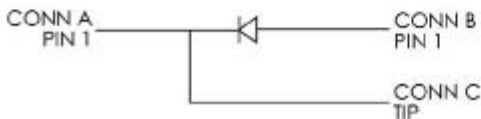













WIRING DIAGRAM:

CONN A	NAME	WIRE	COLOR	CONN B	WIRE	COLOR	CONN C
1	NC	24AWG	RED	1	24AWG	RED	TIP
2	TX	28AWG	BROWN	2			
3	RX	28AWG	ORANGE	3			
4	NC						
5	NC						
6	NC						
7	NC						
8	GND	24AWG	BLACK	5	24AWG	BLACK	RING
9	NC						
SHELL	—	DRAIN	BARE	SHELL			

* SEE WIRING DIAGRAM BELOW FOR CONN A PIN 1, CONN B PIN 1 AND CONN C TIP



Appendix C — Configuration Symbols

 M001_01 Global Optimization - A1	 M002_01 Global Optimization - A2	 M003_01 Global Optimization - A3	 M004_01 Global Optimization - B1
 M005_01 Global Optimization - B2	 M006_01 Global Optimization - B3	 M007_01 Global Optimization - C1	 M008_01 Global Optimization - C2
 M009_01 Global Optimization - C3	 M010_01 Global Optimization - D1	 M011_01 Global Optimization - D2	 M012_01 Global Optimization - D3
 M013_01 Handle Trigger Opt. - A1	 M014_01 Handle Trigger Opt. - A2	 M015_01 Handle Trigger Opt. - A3	 M016_01 Handle Trigger Opt. - B1
 M017_01 Handle Trigger Opt. - B2	 M018_01 Handle Trigger Opt. - B3	 M019_01 Handle Trigger Opt. - C1	 M020_01 Handle Trigger Opt. - C2



Save Settings



Default to USB



Default to PS/2























Clear All Data



Clear XML Rules

Configuration Symbols

 M021_01 Handle Trigger Opt. - C3	 M022_01 Handle Trigger Opt. - D1	 M023_01 Handle Trigger Opt. - D2	 M024_01 Handle Trigger Opt. - D3
 M025_01 Left Button Opt. - A1	 M026_01 Left Button Opt. - A2	 M027_01 Left Button Opt. - A3	 M028_01 Left Button Opt. - B1
 M029_01 Left Button Opt. - B2	 M030_01 Left Button Opt. - B3	 M031_01 Left Button Opt. - C1	 M032_01 Left Button Opt. - C2
 M033_01 Left Button Opt. - C3	 M034_01 Left Button Opt. - D1	 M035_01 Left Button Opt. - D2	 M036_01 Left Button Opt. - D3
 M037_01 Right Button Opt. - A1	 M038_01 Right Button Opt. - A2	 M039_01 Right Button Opt. - A3	 M040_01 Right Button Opt. - B1



Save Settings

M188_02



Default to USB

M049_03



Default to PS/2

M060_03





















Clear All Data

M071_01



Clear XML Rules

M052_01

 M041_01 Right Button Opt. - B2	 M042_01 Right Button Opt. - B3	 M043_01 Right Button Opt. - C1	 M044_01 Right Button Opt. - C2
 M045_01 Right Button Opt. - C3	 M046_01 Right Button Opt. - D1	 M047_01 Right Button Opt. - D2	 M048_01 Right Button Opt. - D3
 M049_03 Default to USB	 M050_01 Clear Memory	 M051_01 Clear RF Settings	 M052_01 Clear XML Rules
	 M054_01 Laser Settings - Off	 M055_01 Laser Settings - On	 M056_01 Laser Settings - Low (1%)
 M057_01 Laser Settings - Medium (80%)	 M058_01 Laser Settings - High (100%)	 M059_01 Modem Setting: spx15200:8N1	 M060_03 Default to PS/2



Save Settings



Default to USB



Default to PS/2



Clear All Data



Clear XML Rules

Configuration Symbols

 M061_02 Symbol Readability Index	 M062_02 Symbol Readability Index Output Enable	 M063_02 Symbol Readability Index Output Disable	 M064_01 USB Image Upload
 M065_01 Bluetooth Radio Auto-Disconnect Off	 M066_01 Bluetooth Radio Auto-Disconnect On	 M067_01 Bluetooth Radio Auto-Connect Off	 M068_01 Bluetooth Radio Auto-Connect On
 M069_01 Disable Auto-Transfer Buffer Memory	 M070_01 Enable Auto-Transfer Buffer Memory	 M071_01 Clear All Stored Data	 M072_01 Log Only Mode
 M073_02 RS-232 Batch	 M074_02 RS-232 Cabled	 M075_01 Send and Buffer Mode	 M076_01 Send and Log Mode
 M077_02 Transfer All Data in Memory	 M078_02 Transfer Only Unsent Data in Memory	 M079_01 Continuous Trigger Optimization - A1	 M080_01 Continuous Trigger Optimization - A2



M188_02

Save Settings



M049_03

Default to USB



M060_03

Default to PS/2







M071_01

Clear All Data



M052_01

Clear XML Rules

 M081_01 Continuous Trigger Optimization - A3	 M082_01 Continuous Trigger Optimization - B1	 M083_01 Continuous Trigger Optimization - B2	 M084_01 Continuous Trigger Optimization - B3
 M085_01 Continuous Trigger Optimization - C1	 M086_01 Continuous Trigger Optimization - C2	 M087_01 Continuous Trigger Optimization - C3	 M088_01 Continuous Trigger Optimization - D1
 M089_01 Continuous Trigger Optimization - D2	 M090_01 Continuous Trigger Optimization - D3	 M091_01 Continuous Trigger Off	 M092_01 RS-232 Interface - Baud Rate - 1200
 M093_01 RS-232 Interface - Baud Rate - 2400	 M094_01 RS-232 Interface - Baud Rate - 4800	 M095_01 RS-232 Interface - Baud Rate - 9600	 M096_01 RS-232 Interface - Baud Rate - 19200
 M097_01 RS-232 Interface - Baud Rate - 38400	 M098_01 RS-232 Interface - Baud Rate - 57600	 M099_01 RS-232 Interface - Baud Rate - 115200	 M100_01 RS-232 Interface - Data Bits - 7



Save Settings



Default to USB



Default to PS/2











Clear All Data



Clear XML Rules

Configuration Symbols

 M101_01 RS-232 Interface - Data Bits - 8	 M102_01 RS-232 Interface - Parity - Even	 M103_01 RS-232 Interface - Parity - None	 M104_01 RS-232 Interface - Parity - Odd
 M105_01 RS-232 Interface - Data Bits - 1	 M106_01 RS-232 Interface - Data Bits - 2	 M107_01 Vibrate On / Beep On	 M108_01 Vibrate Off / Beep On
 M109_01 Vibrate On / Beep Off	 M110_01 Beep Off	 M111_01 Beep Quiet	 M112_01 Beep Loud
 M113_01 Disable Pair, Auth., Encrypt	 M114_02 Disconnect from Bluetooth	 M115_01 Encrypt, Enable Pairing, Auth.	 M116_01 Inquire and Connect
 M117_01 Enable Pairing	 M118_01 RF Com Enable	 M119_01 Bluetooth Radio - Time Out - 1 Hour	 M120_01 Bluetooth Radio - Time Out - 2 Hours



Save Settings

M188_02



Default to USB

M049_03



Default to PS/2

M060_03





















Clear All Data

M071_01



Clear XML Rules

M052_01

 M121_01 Bluetooth Radio - Time Out - 5 Minutes	 M122_01 Bluetooth Radio - Time Out - 10 Minutes	 M123_01 Bluetooth Radio - Time Out - 15 Minutes	 M124_01 Bluetooth Radio - Time Out - 30 Minutes
 M125_01 Bluetooth Radio - Time Out - 90 Minutes	 M126_01 PS/2 Mode	 M127_01 RF One-Way Mode - Max Range	 M128_01 RF One-Way Mode - Max Reliability
 M129_02 RF Two-Way Mode	 M130_01 RF Enabled		 M132_01 RS-232 Two-Way Mode
 M133_01 USB Downloader Mode	 M134_02 USB Keyboard Mode	 M135_04 USB Native Two-Way Mode	 M136_01 Cable Active - Sleep Time Out - Cabled - 2 Hours
 M137_01 Cable Active - Sleep Time Out - Cabled - Always	 M138_02 Continuous Read - Near and Far Fields	 M139_02 Continuous Read - Far Field Only	 M140_02 Continuous Read - Near Field Only



Save Settings



Default to USB



Default to PS/2





















Clear All Data



Clear XML Rules

Configuration Symbols

 M141_03 Continuous Read - Off	 M142_01 Continuous Read - Trigger Delays - 0 Seconds	 M143_01 Continuous Read - Trigger Delays - 1 Second	 M144_01 Continuous Read - Trigger Delays - 3 Seconds
 M145_01 Continuous Read - Sleep Time Out - Uncabled - 5 Minutes	 M146_01 Continuous Read - Sleep Time Out - Uncabled - 15 Minutes	 M147_01 Continuous Read - Sleep Time Out - Uncabled - 30 Minutes	 M148_01 Extra-Long Decode Time (Double)
 M149_01 LEDs for Non-Standard Inks Off	 M150_01 LEDs for Non-Standard Inks On	 M151_01 Long Decode Time	 M152_01 Normal Decode Time
 M153_01 Imager ID and Firmware	 M154_04 Handle Trigger - Take Picture	 M155_03 Handle Trigger - Far Field Only	 M156_03 Handle Trigger - Near Field Only
 M157_03 Handle Trigger - Near and Far Fields		 M159_02 Preamble - Comma	 M160_04 Postamble - Comma



Save Settings



Default to USB













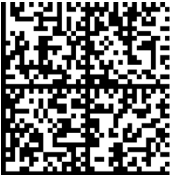

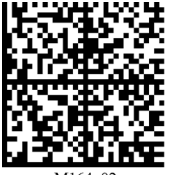



Default to PS/2



Clear All Data



Clear XML Rules

 M161_04 Postamble - Enter	 M162_01 Preamble - Erase/None	 M163_01 Postamble - Erase/None	 M164_02 Preamble - Space
 M165_04 Postamble - Space	 M166_01 Preamble - Tab - USB Keyboard Mode	 M167_04 Postamble - Tab - USB Keyboard Mode	 M168_04 Postamble - Carriage Return - Serial Mode
 M169_04 Postamble - Line Feed - Serial Mode	 M170_04 Postamble - CRLF - Serial Mode	 M171_01 Custom Keyboard	 M172_01 US Keyboard Mapping with Leading 0 in Alt + Num
 M173_01 Universal Keyboard Mapping	 M174_01 Control LEDs Separately - False	 M175_01 Control LEDs Separately - True	 M176_01 Left Button - Far Field Only
 M177_01 Left Button - Near Field Only	 M178_01 Left Button - Near and Far Fields	 M179_01 Left Button - Take Picture	



Save
Settings



Default
to USB



Default
to PS/2





















Clear
All Data



Clear
XML
Rules

Configuration Symbols

 M181_02 Mirroring - Off	 M182_01 Mirroring - On	 M183_01 Right Button - Far Field Only	 M184_01 Right Button - Near Field Only
 M185_01 Right Button - Near and Far Fields	 M186_01 Right Button - Take Picture		 M188_02 Save Settings
 M189_01 Set Targeting Zone Tolerances - 50	 M190_01 Set Targeting Zone Tolerances - 75	 M191_01 Set Targeting Zone Tolerances - 100	 M192_01 Set Targeting Zone Tolerances - 125
 M193_01 Set Targeting Zone Tolerances - 150	 M194_01 Set Targeting Zone Tolerances - 400	 M195_01 Set Targeting Zone Tolerances - 200	 M196_01 Set Targeting Zone Tolerances - 1600
 M197_02 Text Commands - Off	 M198_02 Text Commands - On	 M199_02 Time Stamp Settings - Off	 M200_02 Time Stamp Settings - On



Save Settings

M188_02



Default to USB

M049_03



Default to PS/2

M060_03























Clear All Data

M071_01

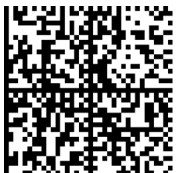

Clear XML Rules

M052_01

 M201_03 Enable SXGA - 1280 x 1024	 M202_03 Enable VGA - 640 x 480 (Rev 5 or earlier only)	 M203_01 Enable SXGA Handle Trigger	 M204_01 Enable VGA Handle Trigger (Rev 5 or earlier only)
 M205_01 Enable SXGA Left Button	 M206_01 Enable VGA Left Button (Rev 5 or earlier only)	 M207_01 Enable SXGA Right Button	 M208_01 Enable VGA Right Button (Rev 5 or earlier only)
 M209_01 1D Symbols Only	 M210_01 Small 2D Symbols	 M211_01 Medium 2D Symbols	 M212_01 Large 2D Symbols
 M213_01 Reset Window to Factory Default	 M214_02 Preamble - CRLF - Serial Mode	 M215_01 Disable Batch	 M216_01 Enable Batch
 M217_01 Short Decode Time (20% Shorter)	 M218_02 Preamble - Tab - RS-232 Serial Mode	 M219_04 Postamble - Tab - RS-232 Serial Mode	 M220_01 No Read Display Off



Save
Settings



Default
to USB



Default
to PS/2

















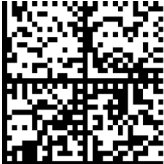



Clear
All Data



Clear
XML
Rules

Configuration Symbols

 M221_01 No Read Display On	 M222_01 Continuous Read - Duplicate Read Delay - 0 Seconds	 M223_01 Continuous Read - Duplicate Read Delay - 1 Second	 M224_01 Continuous Read - Duplicate Read Delay - 3 Seconds
 M225_01 Disable AIM ID Preamble	 M226_01 Enable AIM ID Preamble	 M227_01 RS-232 Downloader 57600 Baud Rate	 M228_01 RS-232 Downloader 115200 Baud Rate
 M229_01 “,” Command - Dump Settings	 M230_01 Batch Enabled	 M231_01 Batch Disabled	 M232_01 Code 39 Extended - Full ASCII Off
 M233_01 Code 39 Extended - Full ASCII On	 M234_01 Code 39 Off	 M235_01 Code 39 On	 M236_01 Code 39 - Disable Checksum
 M237_01 Code 39 - Enable Checksum	 M238_01 Enable Checksum and Strip from Result	 M239_01 Data Matrix Inverse On	 M240_01 Data Matrix Inverse Off



Save Settings

M188_02



Default to USB

M049_03



Default to PS/2

M060_03







Clear All Data

M071_01



Clear XML Rules

M052_01

 <p>M241_01</p> <p>Data Matrix Rectangle Off</p>	 <p>M242_01</p> <p>Data Matrix Rectangle On</p>	 <p>M243_01</p> <p>Interleaved 2 of 5 Off</p>	 <p>M244_01</p> <p>Interleaved 2 of 5 On</p>
 <p>M245_02</p> <p>Interleaved 2 of 5 Two Digits Off</p>	 <p>M246_01</p> <p>Interleaved 2 of 5 Two Digits On</p>	 <p>M247_01</p> <p>Interleaved 2 of 5 Four Digits Off</p>	 <p>M248_01</p> <p>Interleaved 2 of 5 Four Digits On</p>
 <p>M249_01</p> <p>Disable Interleaved 2 of 5 Checksum</p>	 <p>M250_01</p> <p>Enable Interleaved 2 of 5 Checksum</p>	 <p>M251_01</p> <p>Enable Interleaved 2 of 5 Checksum and Strip from Result</p>	 <p>M252_01</p> <p>Postal Symbologies - Australian Post On</p>
 <p>M253_01</p> <p>Postal Symbologies - Japan Post On</p>	 <p>M254_01</p> <p>Postal Symbologies - KIX On</p>	 <p>M255_01</p> <p>Postal Symbologies - Postnet and Planet On</p>	 <p>M256_01</p> <p>Postal Symbologies - Planet On</p>
 <p>M257_01</p> <p>Postal Symbologies - Postnet On</p>	 <p>M258_01</p> <p>Postal Symbologies - Royal Mail On</p>	 <p>M259_01</p> <p>Postal Symbologies - Disable All</p>	 <p>M260_01</p> <p>QR Code - Off</p>



Save Settings



Default to USB



Default to PS/2





















Clear All Data



Clear XML Rules

Configuration Symbols

 M261_01 QR Code - On	 M262_01 QR Code - Inverse On	 M263_01 QR Code - Inverse and Standard On	 M264_01 QR Code - Disable Checksum
 M265_01 QR Code - Enable Checksum	 M266_01 All DataBar Off	 M267_01 All DataBar On	 M268_01 DataBar Limited On
 M269_01 DataBar Expanded On	 M270_01 DataBar-14 Stacked On	 M271_01 DataBar-14 and DataBar-14 Truncated On	 M272_01 Aztec Off
 M273_01 Aztec On	 M274_01 Codabar Off	 M275_01 Codabar On	 M276_01 Codablock F Off
 M277_01 Codablock F On			 M280_01 Code 93 Off



Save Settings

M188_02



Default to USB

M049_03



Default to PS/2

M060_03























Clear All Data

M071_01



Clear XML Rules

M052_01

 M281_02 Code 93 On	 M282_01 Code 128 Off	 M283_01 Code 128 On	 M284_02 Composite Off
 M285_02 Composite On	 M286_01 MacroPDF417 Off	 M287_01 MacroPDF417 On	 M288_01 Maxicode Off
 M289_04 Maxicode On	 M290_01 MSI Plessey Off	 M291_01 MSI Plessey On	 M292_01 PDF417 Off
 M293_01 PDF417 On	 M294_01 UPC Off	 M295_01 UPC On	 M296_01 UPC Extension Off
 M297_01 UPC Extension On	 M298_01 UPC Narrow Margin Disabled	 M299_01 UPC Narrow Margin Enabled	 M300_01 MicroPDF417 Off



Save Settings



Default to USB



Default to PS/2













Clear All Data



Clear XML Rules

Configuration Symbols

 <p>M301_01</p> <p>MicroPDF417 On</p>			
			 <p>M308_03</p> <p>Symbology Identifier (Preamble)</p>
 <p>M313_01</p> <p>Modem - 1200 Baud</p>	 <p>M314_01</p> <p>Modem - 2400 Baud</p>	 <p>M315_01</p> <p>Modem - 4800 Baud</p>	 <p>M316_01</p> <p>Modem - 9600 Baud</p>
 <p>M317_01</p> <p>Modem - 19200 Baud</p>	 <p>M318_01</p> <p>Modem - 38400 Baud</p>	 <p>M319_01</p> <p>Modem - 57600 Baud</p>	 <p>M320_01</p> <p>Modem - 115200 Baud</p>



Save Settings



Default to USB

















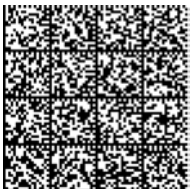



Default to PS/2



Clear All Data



Clear XML Rules

 M321_01 Modem - Modem Firmware Version	 M322_01 Turn Off Illumination	 M323_01 Highly Reflective Surface	 M324_01 Turn On Illumination
 M325_01 Codabar - Remove Start/Stop	 M326_01 Disable Rule 410	 M327_01 Enable Rule 410	 M328_01 AIM ID Config. Pass Through
 M329_01 Modem - 9600 Baud 7E1	 M330_02 Imager ID Preamble	 M331_02 Imager ID Postamble	
 M334_01 Set Time Stamp Value 010000	 M335_01 Set Time Stamp Value 013000	 M336_01 Set Time Stamp Value 020000	 M337_01 Set Time Stamp Value 023000
 M338_01 Set Time Stamp Value 030000	 M339_01 Set Time Stamp Value 033000	 M340_01 Set Time Stamp Value 040000	 M341_01 Set Time Stamp Value 043000



Save Settings



Default to USB



Default to PS/2



Clear All Data



Clear XML Rules

Configuration Symbols

 M342_01 Set Time Stamp Value 050000	 M343_01 Set Time Stamp Value 053000	 M344_01 Set Time Stamp Value 060000	 M345_01 Set Time Stamp Value 063000
 M346_01 Set Time Stamp Value 070000	 M347_01 Set Time Stamp Value 073000	 M348_01 Set Time Stamp Value 080000	 M349_01 Set Time Stamp Value 083000
 M350_01 Set Time Stamp Value 090000	 M351_01 Set Time Stamp Value 093000	 M352_01 Set Time Stamp Value 100000	 M353_01 Set Time Stamp Value 103000
 M354_01 Set Time Stamp Value 110000	 M355_01 Set Time Stamp Value 113000	 M356_01 Set Time Stamp Value 120000	 M357_01 Set Time Stamp Value 123000
 M358_01 Set Time Stamp Value 130000	 M359_01 Set Time Stamp Value 133000	 M360_01 Set Time Stamp Value 140000	 M361_01 Set Time Stamp Value 143000



Save
Settings

M188_02



Default
to USB

M049_03



Default
to PS/2

M060_03





















Clear
All Data

M071_01



Clear
XML
Rules

M052_01

 M362_01 Set Time Stamp Value 150000	 M363_01 Set Time Stamp Value 153000	 M364_01 Set Time Stamp Value 160000	 M365_01 Set Time Stamp Value 163000
 M366_01 Set Time Stamp Value 170000	 M367_01 Set Time Stamp Value 173000	 M368_01 Set Time Stamp Value 180000	 M369_01 Set Time Stamp Value 183000
 M370_01 Set Time Stamp Value 190000	 M371_01 Set Time Stamp Value 193000	 M372_01 Set Time Stamp Value 200000	 M373_01 Set Time Stamp Value 203000
 M374_01 Set Time Stamp Value 210000	 M375_01 Set Time Stamp Value 213000	 M376_01 Set Time Stamp Value 220000	 M377_01 Set Time Stamp Value 223000
 M378_01 Set Time Stamp Value 230000	 M379_01 Set Time Stamp Value 233000		 M381_01 Preamble STX



Save Settings



Default to USB



Default to PS/2











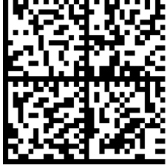









Clear All Data



Clear XML Rules

Configuration Symbols

 M382_01 Postamble ETX	 M383_01 Default to USB with LEDs and Active BT	 M384_01 Default to PS/2 with LEDs and Active BT	 M385_01 Image Uploader - Compressed Image (JPEG)
 M386_01 Image Uploader - Uncompressed Image (BMP)	 M387_01 Image Uploader - Far Field	 M388_01 Image Uploader - Near Field	 M389_01 Code 39 Narrow Margin Disable
 M390_01 Code 39 Narrow Margin Enable	 M391_01 Code 128 Narrow Margin Disable	 M392_01 Code 128 Narrow Margin Enable	 M393_01 Code 11 Disable
 M394_01 Code 11 Enable (Two Checksum Digits Checked)	 M395_01 Code 11 (One Checksum Digit Checked)	 M396_01 Code 11 (Two Checksum Digits Checked and Stripped from Result)	 M397_01 Code 11 (One Checksum Digit Checked and Stripped from Result)
 M398_01 Disable Code 128 Narrow Margin	 M399_01 Enable Code 128 Narrow Margin	 M400_01 Disable Code 39 Narrow Margin	 M401_01 Enable Code 39 Narrow Margin



Save Settings

M188_02



Default to USB

M049_03



Default to PS/2

M060_03























Clear All Data

M071_01















Clear XML Rules

M052_01

 M402_01 Translate CRLF into Enter	 M404_01 Erase Preamble Only	 M405_02 Erase Postamble Only	 M406_02 Erase Preamble and Postamble
 M407_01 Default to Factory Settings, Save Settings, Reboot	 M408_01 Disable Pharmacode	 M409_01 Enable Pharmacode - No Color, Standard Rules, Horiz. Decode, Normal Direction	 M410_01 Enable Pharmacode - Color, Relaxed Contrast, Horiz. Decode, Normal Direction
 M411_01 Enable Pharmacode - No Color, Standard Rules, Vert. Decode, Normal Direction	 M412_01 Enable Pharmacode - Color, Relaxed Contrast, Vert. Decode, Normal Direction	 M413_01 Enable Pharmacode - No Color, Standard Rules, Horiz. Decode, Reverse Direction	 M414_01 Enable Pharmacode - Color, Relaxed Contrast, Horiz. Decode, Reverse Direction
 M415_01 Enable Pharmacode - No Color, Standard Rules, Vert. Decode, Reverse Direction	 M416_01 Enable Pharmacode - Color, Relaxed Contrast, Vert. Decode, Reverse Direction	 M417_01 RS-232 Suppress Imager Responses	 M418_02 Default to RS-232 Factory Settings
 M419_01 RS-232 Enable Imager Responses	 M420_01 Replace All \\ with \ (PDF417)	 M421_01 Top Buttons - Toggle Contin. Trigger On/Off	 M422_01 RF Attempt to Connect Time Out - Default - 30 Seconds



Configuration Symbols

 M423_01 RF Attempt to Connect Time Out - 15 Seconds	 M424_01 USB - Detect Out Endpoint	 M425_01 USB - Use Out Endpoint	 M426_01 USB - Do Not Use Out Endpoint
 M427_01 RF Time Out - 6 Hours	 M428_01 Settings Unlocked (Except Imager ID)	 M429_01 Settings Locked	 M430_01 Reboot Imager
 M432_01 Modem - 1200 Baud	 M433_01 Modem - 1200 Baud	 M434_01 Modem - 1200 Baud	 M435_01 Modem - 1200 Baud
 M436_01 Modem - 1200 Baud	 M437_01 Modem - 1200 Baud	 M438_01 Modem - 1200 Baud	 M439_01 Modem - 1200 Baud
 M440_01 Modem - 1200 Baud	 M441_01 Modem - 1200 Baud	 M442_01 Modem - 1200 Baud	 M443_01 Modem - 1200 Baud



Save
Settings

M188_02



Default
to USB

M049_03



Default
to PS/2

M060_03























Clear
All Data

M071_01





















Clear
XML
Rules

M052_01

 M444_01 Modem - 1200 Baud	 M445_01 Modem - 1200 Baud	 M446_01 Modem - 1200 Baud	 M447_01 Modem - 1200 Baud
 M448_01 Modem - 1200 Baud	 M449_01 Modem - 2400 Baud	 M450_01 Modem - 2400 Baud	 M451_01 Modem - 2400 Baud
 M452_01 Modem - 2400 Baud	 M453_01 Modem - 2400 Baud	 M454_01 Modem - 2400 Baud	 M455_01 Modem - 2400 Baud
 M456_01 Modem - 2400 Baud	 M457_01 Modem - 2400 Baud	 M458_01 Modem - 2400 Baud	 M459_01 Modem - 2400 Baud
 M460_01 Modem - 2400 Baud	 M461_01 Modem - 2400 Baud	 M462_01 Modem - 2400 Baud	 M463_01 Modem - 2400 Baud



Configuration Symbols

 M464_01 Modem - 2400 Baud	 M465_01 Modem - 2400 Baud	 M466_01 Modem - 4800 Baud	 M467_01 Modem - 4800 Baud
 M468_01 Modem - 4800 Baud	 M469_01 Modem - 4800 Baud	 M470_01 Modem - 4800 Baud	 M471_01 Modem - 4800 Baud
 M472_01 Modem - 4800 Baud	 M473_01 Modem - 4800 Baud	 M474_01 Modem - 4800 Baud	 M475_01 Modem - 4800 Baud
 M476_01 Modem - 4800 Baud	 M477_01 Modem - 4800 Baud	 M478_01 Modem - 4800 Baud	 M479_01 Modem - 4800 Baud
 M480_01 Modem - 4800 Baud	 M481_01 Modem - 4800 Baud	 M482_01 Modem - 4800 Baud	 M483_01 Modem - 9600 Baud



Save Settings

M188_02



Default to USB

M049_03



Default to PS/2

M060_03























Clear All Data

M071_01



Clear XML Rules

M052_01

 M484_01 Modem - 9600 Baud	 M485_01 Modem - 9600 Baud	 M486_01 Modem - 9600 Baud	 M487_01 Modem - 9600 Baud
 M488_01 Modem - 9600 Baud	 M489_01 Modem - 9600 Baud	 M490_01 Modem - 9600 Baud	 M491_01 Modem - 9600 Baud
 M492_01 Modem - 9600 Baud	 M493_01 Modem - 9600 Baud	 M494_01 Modem - 9600 Baud	 M495_01 Modem - 9600 Baud
 M496_01 Modem - 9600 Baud	 M497_01 Modem - 9600 Baud	 M498_01 Modem - 9600 Baud	 M499_01 Modem - 9600 Baud
 M500_01 Modem - 19200 Baud	 M501_01 Modem - 19200 Baud	 M502_01 Modem - 19200 Baud	 M503_01 Modem - 19200 Baud



Configuration Symbols

 M504_01 Modem - 19200 Baud	 M505_01 Modem - 19200 Baud	 M506_01 Modem - 19200 Baud	 M507_01 Modem - 19200 Baud
 M508_01 Modem - 19200 Baud	 M509_01 Modem - 19200 Baud	 M510_01 Modem - 19200 Baud	 M511_01 Modem - 19200 Baud
 M512_01 Modem - 19200 Baud	 M513_01 Modem - 19200 Baud	 M514_01 Modem - 19200 Baud	 M515_01 Modem - 19200 Baud
 M516_01 Modem - 19200 Baud	 M517_01 Modem - 38400 Baud	 M518_01 Modem - 38400 Baud	 M519_01 Modem - 38400 Baud
 M520_01 Modem - 38400 Baud	 M521_01 Modem - 38400 Baud	 M522_01 Modem - 38400 Baud	 M523_01 Modem - 38400 Baud



Save Settings

M188_02



Default to USB

M049_03



Default to PS/2

M060_03



















Clear All Data

M071_01



Clear XML Rules

M052_01

 M524_01 Modem - 38400 Baud	 M525_01 Modem - 38400 Baud	 M526_01 Modem - 38400 Baud	 M527_01 Modem - 38400 Baud
 M528_01 Modem - 38400 Baud	 M529_01 Modem - 38400 Baud	 M530_01 Modem - 38400 Baud	 M531_01 Modem - 38400 Baud
 M532_01 Modem - 38400 Baud	 M533_01 Modem - 38400 Baud	 M534_01 Modem - 57600 Baud	 M535_01 Modem - 57600 Baud
 M536_01 Modem - 57600 Baud	 M537_01 Modem - 57600 Baud	 M538_01 Modem - 57600 Baud	 M539_01 Modem - 57600 Baud
 M540_01 Modem - 57600 Baud	 M541_01 Modem - 57600 Baud	 M542_01 Modem - 57600 Baud	 M543_01 Modem - 57600 Baud



Save Settings



Default to USB



Default to PS/2



Clear All Data



Clear XML Rules

Configuration Symbols

 M544_01 Modem - 57600 Baud	 M545_01 Modem - 57600 Baud	 M546_01 Modem - 57600 Baud	 M547_01 Modem - 57600 Baud
 M548_01 Modem - 57600 Baud	 M549_01 Modem - 57600 Baud	 M550_01 Modem - 57600 Baud	 M551_01 Modem - 115200 Baud
 M552_01 Modem - 115200 Baud	 M553_01 Modem - 115200 Baud	 M554_01 Modem - 115200 Baud	 M555_01 Modem - 115200 Baud
 M556_01 Modem - 115200 Baud	 M557_01 Modem - 115200 Baud	 M558_01 Modem - 115200 Baud	 M559_01 Modem - 115200 Baud
 M560_01 Modem - 115200 Baud	 M561_01 Modem - 115200 Baud	 M562_01 Modem - 115200 Baud	 M563_01 Modem - 115200 Baud



Save Settings

M188_02



Default to USB

M049_03



Default to PS/2

M060_03

















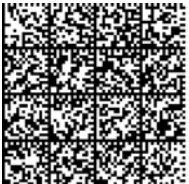

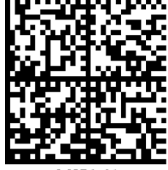

Clear All Data

M071_01



Clear XML Rules

M052_01

 M564_01 Modem - 115200 Baud	 M565_01 Modem - 115200 Baud	 M566_01 Modem - 115200 Baud	 M567_01 Modem - 115200 Baud
 m568_01 Dump Setting Command	 M569_02 Maxicode - Secondary Data Pass Through	 suffixcolon Append ":" to Postamble	 prefixreaderId Append Imager ID to Preamble
 suffixreaderId Append Imager ID to Postamble	 prefixcolon Append ":" to Preamble	 M576_01 Append Symbology to Postamble	 M577_01 Save Settings Using "~"
 Append ":" to Preamble - Serial Mode	 M579_02 Illumination Flash On Event	 M580_02 Illumination Constant On Event	 M581_01 RF Range Notification Off
 M582_01 RF Range Notification - Vibrate	 M583_01 RF Range Notification - Beep	 M584_02 USB Kb Enumerate on Preset LED - Disable Alternate OS Compatibility	 M585_02 USB Kb Enumerate on Preset LED - Enable Alternate OS Compatibility



Save Settings



Default to USB



Default to PS/2























Clear All Data



Clear XML Rules

Configuration Symbols

 M586_01 Default to Factory RF One-Way Settings	 M587_01 RF Range Notification - Beep and Vibrate	 M589_01 Tab Keystroke	 M590_01 PS/2 Modem - English Keyboard Map with Leading 0 for Non-Printable ASCII
 M591_01 PS/2 Modem - Universal Keyboard Map when in RF Mode	 M592_01 PS/2 Modem - Custom Keyboard Map	 M593_01 PS/2 Modem - English Keyboard Map without Leading 0 for Non-Printable ASCII	 M594_01 PS/2 Modem - French Keyboard Map
 M595_01 PS/2 Modem - German Keyboard Map	 M596_01 PS/2 Modem - Japanese Keyboard Map	 M597_01 PS/2 Modem - Ctrl + Char. for Non-Printable ASCII	 M598_01 USB Polling Speed - 10 mS
 M599_01 USB Polling Speed - 20 mS	 M600_01 USB Polling Speed - 30 mS	 M602_01 US English Keyboard Map Without Leading 0	 M603_01 French Keyboard Mapping
 M604_01 German Keyboard Mapping	 M605_01 Japanese Keyboard Mapping	 M606_01 US English Keyboard Map with Ctrl + Char. for Non-Printable ASCII	 M607_01 Full Field Image Capture (1280 x 1024)



Save Settings

M188_02



Default to USB

M049_03



Default to PS/2

M060_03























Clear All Data

M071_01





















Clear XML Rules

M052_01

 M608_01 Duplicate Read Delay - 300 Seconds	 M609_03 Enable Micro QR Code	 M610_01 Show Bluetooth Access in Modem	 M658_01 AGC Enable Version 1
 M659_01 AGC Enable Version 0 (Legacy)	 M667_01 Enable QR Code and Micro QR Code	 M668_01 USB Virtual COM Port One-Way Mode	 M669_01 USB Virtual COM Port Two-Way Mode
 M670_01 Trioptic Code 39 Off	 M671_01 Trioptic Code 39 On	 M672_01 NEC 2 of 5 Off	 M673_01 NEC 2 of 5 On
 M674_01 Matrix 2 of 5 Off	 M675_01 Matrix 2 of 5 On	 M684_01 RF Factory Defaults	 M685_01 Interleaved 2 of 5 with Control Character Stripped from Result
 M687_03 Enable Micro QR Code Standard and Inverse	 M692_01 Boot Mode	 M693_01 PS/2 Interscan Delay - 5 mS	 M694_01 PS/2 Interscan Delay - 10 mS



Configuration Symbols

 M695_01 PS/2 Interscan Delay - 100 mS	 M696_01 Clear All JavaScript Files	 M701_01 Enable Motion Detection - Near and Far Fields	 M702_01 Disable Motion Detection
 M704_01 Disable Bluetooth Connection While Charging	 M705_01 Enable Bluetooth Connection While Charging	 M706_02 Enable Time Stamp - Time Clock Preamble	 M707_03 Disable Time Stamp - Time Clock Preamble
 M708_01 USB Bluetooth Mode	 M710_02 Lockout Link Mode	 M711_01 Unlock Link	
 M738_01 Enable Background Capture	 M739_01 Disable Background Capture	 M742_01 Modem Pre-Emptible	 M743_01 Modem Non-Pre-Emptible
 M744_01 Enable Data Matrix Improvements	 M745_01 Disable Data Matrix Improvements	 M746_01 Enable Auto-Save Last Bluetooth Address	 M747_01 Disable Auto-Save Last Bluetooth Address



Save
Settings



Default
to USB













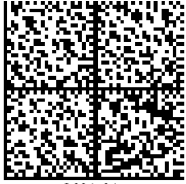









Default
to PS/2

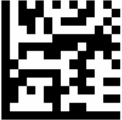

Clear
All Data















Clear
XML
Rules

 Q001_01 Enable Left Button Mode Switching	 Q002_01 Change IP Mode - Quadrus Only Mode	 Q003_01 Change IP Mode - Quadrus Mode 1	 Q004_01 Change IP Mode - Standard Mode
 Q005_01 ECC 0-140 On	 Q006_01 ECC 0-140 Off	 Q007_01 Default LEDs	 Q008_01 IR LEDs Off, Visible LEDs On
 Q009_01 Visible LEDs Off, IR LEDs On (Near IR LEDs Off)	 Q010_01 Control IR LEDs Separately (Lower Intensity IR)	 Q011_01 Disable Left Button	 Q012_01 Disable Right Button
 Q013_01 Disable Left and Right Buttons	 Q014_01 UII-Only Enabled	 Q015_01 UII-Only Enabled with Error Messaging	 Q016_01 UII Enabled with Pass Through
 Q017_01 UII Enabled with Error Messaging and Pass Through	 Q018_01 UII Disabled	 M069_03 Enable 2-Symbol Read	 M052_01 Disable 2-Symbol Read

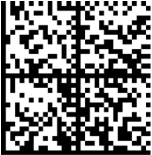

Configuration Symbols

			
Laser Off, Visible LEDs Off, IR LEDs On at 100%	Laser On, Visible LEDs Off, IR LEDs On at 100%	Laser Off, All LEDs On at 100%	Laser On, All LEDs On at 100%
			
USB Battery Charge Mode	Default to Previous Settings (Disable USB Battery Charge Mode)	Laser Off, Control IR Separately in Both Fields	Laser On, Control IR Separately in Both Fields
			
Q029_01 RS-232 Connect Mode	Q030_01 USB Connect Mode	Enable MIL-STD-130M	Enable MIL-STD-130N
			
MS101_01 RS-232 Default Settings Mode			



Save Settings

M188_02



Default to USB

M049_03



Default to PS/2

M060_03



Clear All Data

M071_01



Clear XML Rules

M052_01

Appendix D — Configuration Symbol Reference List

M001_01	Global Optimization - A1
M002_01	Global Optimization - A2
M003_01	Global Optimization - A3
M004_01	Global Optimization - B1
M005_01	Global Optimization - B2
M006_01	Global Optimization - B3
M007_01	Global Optimization - C1
M008_01	Global Optimization - C2
M009_01	Global Optimization - C3
M010_01	Global Optimization - D1
M011_01	Global Optimization - D2
M012_01	Global Optimization - D3
M013_01	Handle Trigger Optimization - A1
M014_01	Handle Trigger Optimization - A2
M015_01	Handle Trigger Optimization - A3
M016_01	Handle Trigger Optimization - B1
M017_01	Handle Trigger Optimization - B2
M018_01	Handle Trigger Optimization - B3
M019_01	Handle Trigger Optimization - C1
M020_01	Handle Trigger Optimization - C2
M021_01	Handle Trigger Optimization - C3
M022_01	Handle Trigger Optimization - D1
M023_01	Handle Trigger Optimization - D2
M024_01	Handle Trigger Optimization - D3
M025_01	Left Button Optimization - A1
M026_01	Left Button Optimization - A2
M027_01	Left Button Optimization - A3
M028_01	Left Button Optimization - B1
M029_01	Left Button Optimization - B2
M030_01	Left Button Optimization - B3
M031_01	Left Button Optimization - C1
M032_01	Left Button Optimization - C2
M033_01	Left Button Optimization - C3
M034_01	Left Button Optimization - D1
M035_01	Left Button Optimization - D2
M036_01	Left Button Optimization - D3
M037_01	Right Button Optimization - A1
M038_01	Right Button Optimization - A2

Configuration Symbol Reference List

M039_01	Right Button Optimization - A3
M040_01	Right Button Optimization - B1
M041_01	Right Button Optimization - B2
M042_01	Right Button Optimization - B3
M043_01	Right Button Optimization - C1
M044_01	Right Button Optimization - C2
M045_01	Right Button Optimization - C3
M046_01	Right Button Optimization - D1
M047_01	Right Button Optimization - D2
M048_01	Right Button Optimization - D3
M049_03	Default to USB
M050_01	Clear Memory
M051_02	Clear RF Settings
M052_01	Clear XML Rules, Including Preamble and Postamble
M054_01	Laser Settings - Off
M055_01	Laser Settings - On
M056_01	Laser Settings - Low (1%)
M057_01	Laser Settings - Medium (80%)
M058_01	Laser Settings - High (100%)
M059_01	Modem Setting spx15200:8N1
M060_03	Default to PS/2
M061_02	Symbol Readability Index
M062_02	Symbol Readability Index Output Enable
M063_02	Symbol Readability Index Output Disable
M064_01	USB Image Upload
M065_01	Bluetooth Radio Auto-Disconnect Off
M066_01	Bluetooth Radio Auto-Disconnect On
M067_01	Bluetooth Radio Auto-Connect Off
M068_01	Bluetooth Radio Auto-Connect On
M069_01	Disable Auto-Transfer Buffer Memory
M070_01	Enable Auto-Transfer Buffer Memory
M071_01	Clear All Stored Data
M072_01	Log Only Mode
M073_02	RS-232 Batch
M074_02	RS-232 Cabled
M075_01	Send and Buffer Mode
M076_01	Send and Log Mode
M077_02	Transfer All Data in Memory
M078_02	Transfer Only Unsent Data in Memory
M079_01	Continuous Trigger Optimization - A1

M080_01	Continuous Trigger Optimization - A2
M081_01	Continuous Trigger Optimization - A3
M082_01	Continuous Trigger Optimization - B1
M083_01	Continuous Trigger Optimization - B2
M084_01	Continuous Trigger Optimization - B3
M085_01	Continuous Trigger Optimization - C1
M086_01	Continuous Trigger Optimization - C2
M087_01	Continuous Trigger Optimization - C3
M088_01	Continuous Trigger Optimization - D1
M089_01	Continuous Trigger Optimization - D2
M090_01	Continuous Trigger Optimization - D3
M091_01	Continuous Trigger Off
M092_01	RS-232 Interface - Baud Rate - 1200
M093_01	RS-232 Interface - Baud Rate - 2400
M094_01	RS-232 Interface - Baud Rate - 4800
M095_01	RS-232 Interface - Baud Rate - 9600
M096_01	RS-232 Interface - Baud Rate - 19200
M097_01	RS-232 Interface - Baud Rate - 38400
M098_01	RS-232 Interface - Baud Rate - 57600
M099_01	RS-232 Interface - Baud Rate - 115200
M100_01	RS-232 Interface - Data Bits - 7
M101_01	RS-232 Interface - Data Bits - 8
M102_01	RS-232 Interface - Parity - Even
M103_01	RS-232 Interface - Parity - None
M104_01	RS-232 Interface - Parity - Odd
M105_01	RS-232 Interface - Data Bits - 1
M106_01	RS-232 Interface - Data Bits - 2
M107_01	Vibrate On / Beep On
M108_01	Vibrate Off / Beep On
M109_01	Vibrate On / Beep Off
M110_01	Beep Off
M111_01	Beep Quiet
M112_01	Beep Loud
M113_01	Disable Pair, Auth., Encrypt
M114_02	Disconnect from Bluetooth
M115_01	Encrypt, Enable Pairing, Auth.
M116_01	Inquire and Connect
M117_01	Enable Pairing
M118_01	RF Com Enable
M119_01	Bluetooth Radio - Time Out - 1 Hour

Configuration Symbol Reference List

M120_01	Bluetooth Radio - Time Out - 2 Hours
M121_01	Bluetooth Radio - Time Out - 5 Minutes
M122_01	Bluetooth Radio - Time Out - 10 Minutes
M123_01	Bluetooth Radio - Time Out - 15 Minutes
M124_01	Bluetooth Radio - Time Out - 30 Minutes
M125_01	Bluetooth Radio - Time Out - 90 Seconds
M126_01	PS/2 Mode
M127_01	RF One-Way Mode - Max Range
M128_01	RF One-Way Mode - Max Reliability
M129_02	RF Two-Way Mode
M130_01	RF Com Enable
M132_01	RS-232 Two-Way Mode
M133_01	USB Downloader Mode
M134_02	USB Keyboard Mode
M135_04	USB Native Two-Way Mode
M136_01	Cable Active - Sleep Time Out - Cabled - 2 hours
M137_01	Cable Active - Sleep Time Out - Cabled - Always
M138_02	Continuous Read - Near and Far Fields
M139_02	Continuous Read - Far Field Only
M140_02	Continuous Read - Near Field Only
M141_03	Continuous Read - Off
M142_01	Continuous Read - Trigger Delays - 0 Seconds
M143_01	Continuous Read - Trigger Delays - 1 Second
M144_01	Continuous Read - Trigger Delays - 3 Seconds
M145_01	Continuous Read - Sleep Time Out - Uncabled - 5 Minutes
M146_01	Continuous Read - Sleep Time Out - Uncabled - 15 Minutes
M147_01	Continuous Read - Sleep Time Out - Uncabled - 30 Minutes
M148_01	Extra Long Decode Time (Double)
M149_01	LEDs for Non-Standard Inks Off
M150_01	LEDs for Non-Standard Inks On
M151_01	Long Decode Time
M152_01	Normal Decode Time
M153_01	Imager ID and Firmware
M154_04	Handle Trigger - Take Picture
M155_03	Handle Trigger - Far Field Only
M156_03	Handle Trigger - Near Field Only
M157_03	Handle Trigger - Near and Far Fields
M159_02	Preamble - Comma
M160_04	Postamble - Comma
M161_04	Postamble - Enter

M162_01	Preamble - Erase/None
M163_01	Postamble - Erase/None
M164_02	Preamble - Space
M165_04	Postamble - Space
M166_01	Preamble - Tab - USB Keyboard Mode
M167_04	Postamble - Tab - USB Keyboard Mode
M168_04	Postamble - Carriage Return - Serial Mode
M169_04	Postamble - Line Feed - Serial Mode
M170_04	Postamble - Carriage Return Line Feed - Serial Mode
M171_01	Custom Keyboard
M172_01	US Keyboard Mapping
M173_01	Universal Keyboard Mapping
M174_01	Control LEDs Separately False
M175_01	Control LEDs Separately True
M176_01	Left Button - Far Field Only
M177_01	Left Button - Near Field Only
M178_01	Left Button - Near and Far Fields
M179_01	Left Button - Take Picture
M181_02	Mirroring - Off
M182_01	Mirroring - On
M183_01	Right Button - Far Field Only
M184_01	Right Button - Near Field Only
M185_01	Right Button - Near and Far Fields
M186_01	Right Button - Take Picture
M188_02	Save Settings
M189_01	Set Targeting Zone Tolerances - 50
M190_01	Set Targeting Zone Tolerances - 75
M191_01	Set Targeting Zone Tolerances - 100
M192_01	Set Targeting Zone Tolerances - 125
M193_01	Set Targeting Zone Tolerances - 150
M194_01	Set Targeting Zone Tolerances - 400
M195_01	Set Targeting Zone Tolerances - 200
M196_01	Set Targeting Zone Tolerances - 1600
M197_02	Text Commands - Off
M198_02	Text Commands - On
M199_02	Time Stamp Settings - Off
M200_02	Time Stamp Settings - On
M201_03	Enable SXGA - 1280 x 1024
M202_03	Enable VGA - 640 x 480 (Rev 5 hardware or earlier only)
M203_01	Enable SXGA Handle Trigger

Configuration Symbol Reference List

M204_01	Enable VGA Handle Trigger (Rev 5 hardware or earlier only)
M205_01	Enable SXGA Left Button
M206_01	Enable VGA Left Button (Rev 5 hardware or earlier only)
M207_01	Enable SXGA Right Button
M208_01	Enable VGA Right Button (Rev 5 hardware or earlier only)
M209_01	1D Symbols Only
M210_01	Small 2D Symbols
M211_01	Medium 2D Symbols
M212_01	Large 2D Symbols
M213_01	Reset Window to Factory Default
M214_02	Preamble - Carriage Return Line Feed - Serial Mode
M215_01	Disable Batch
M216_01	Enable Batch
M217_01	Short Decode Time (20% Shorter)
M218_02	Preamble - Tab - RS-232 Serial Mode
M219_04	Postamble - Tab - RS-232 Serial Mode
M220_01	No Read Display Off
M221_01	No Read Display On
M222_01	Continuous Read - Duplicate Read Delay - 0 Seconds
M223_01	Continuous Read - Duplicate Read Delay - 1 Second
M224_01	Continuous Read - Duplicate Read Delay - 3 Seconds
M225_01	Disable AIM ID Preamble
M226_01	Enable AIM ID Preamble
M227_01	RS-232 Downloader 57600 Baud Rate
M228_01	RS-232 Downloader 115200 Baud Rate
M229_01	"," command - Dump Settings
M230_01	Batch Enabled
M231_01	Batch Disabled
M232_01	Code 39 Extended Full ASCII Off
M233_01	Code 39 Extended Full ASCII On
M234_01	Code 39 Off
M235_01	Code 39 On
M236_01	Code 39 - Disable Checksum
M237_01	Code 39 - Enable Checksum
M238_01	Enable Checksum and Strip From Result
M239_01	Data Matrix Inverse On
M240_01	Data Matrix Inverse Off
M241_01	Data Matrix Rectangle Off
M242_01	Data Matrix Rectangle On
M243_01	Interleaved 2 of 5 Off

M244_02	Interleaved 2 of 5 On
M245_02	Interleaved 2 of 5 Two Digits Off
M246_01	Interleaved 2 of 5 Two Digits On
M247_02	Interleaved 2 of 5 Four Digits Off
M248_01	Interleaved 2 of 5 Four Digits On
M249_01	Disable Interleaved 2of 5 Checksum
M250_01	Enable Interleaved 2of 5 Checksum
M251_01	Enable Interleaved 2of 5 Checksum and Remove
M252_01	Postal Symbologies - Australian Post On
M253_01	Postal Symbologies - Japan Post On
M254_01	Postal Symbologies - KIX
M255_01	Postal Symbologies - Postnet and Planet On
M256_01	Postal Symbologies - Planet On
M257_01	Postal Symbologies - Postnet On
M258_01	Postal Symbologies - Royal Mail On
M259_01	Postal Symbologies - Disable All Postal Symbologies
M260_01	QR Code Off
M261_01	QR Code On
M262_01	QR Code Inverse On
M263_01	Both Inverse and Standard On
M264_01	QR Code - Disable Checksum
M265_01	QR Code - Enable Checksum
M266_01	All DataBar Off
M267_01	All DataBar On
M268_01	DataBar Limited On
M269_01	DataBar Expanded On
M270_01	DataBar-14 Stacked On
M271_01	DataBar-14 and DataBar-14 Truncated On
M272_01	Aztec Off
M273_01	Aztec On
M274_01	Codabar Off
M275_01	Codabar On
M276_01	Codablock F Off
M277_01	Codablock F On
M280_01	Code 93 Off
M281_02	Code 93 On
M282_01	Code 128 Off
M283_01	Code 128 On
M284_02	Composite Off
M285_02	Composite On

Configuration Symbol Reference List

M286_01	MacroPDF417 Off
M287_01	MacroPDF417 On
M288_01	Maxicode Off
M289_04	Maxicode On
M290_01	MSI Plessey Off
M291_01	MSI Plessey On
M292_01	PDF417 Off
M293_01	PDF417 On
M294_01	UPC Off
M295_01	UPC On
M296_01	UPC Extension Off
M297_01	UPC Extension On
M298_01	UPC Narrow Margin Disabled
M299_01	UPC Narrow Margin Enabled
M300_01	MicroPDF417Off
M301_01	MicroPDF417On
M308_03	Symbology Preamble
M313_01	Modem - 1200 baud
M314_01	Modem - 2400 baud
M315_01	Modem - 4800 baud
M316_01	Modem - 9600 baud
M317_01	Modem - 19200 baud
M318_01	Modem - 38400 baud
M319_01	Modem - 57600 baud
M320_01	Modem - 115200 baud
M321_01	Modem - Modem Firmware Version
M322_01	Turn Off Illumination
M323_01	Highly Reflective Surface
M324_01	Turn On Illumination
M325_01	Codabar Remove Start/Stop
M326_01	Disable Rule 410
M327_01	Enable Rule 410
M328_01	AIM ID Config. Pass Through
M329_01	Modem - 9600 baud 7 E 1
M330_02	Imager ID Preamble
M331_02	Imager ID Postamble
M334_01	Set TimeStamp Value 010000
M335_01	Set TimeStamp Value 013000
M336_01	Set TimeStamp Value 020000
M337_01	Set TimeStamp Value 023000

M338_01 Set TimeStamp Value 030000
M339_01 Set TimeStamp Value 033000
M340_01 Set TimeStamp Value 040000
M341_01 Set TimeStamp Value 043000
M342_01 Set TimeStamp Value 050000
M343_01 Set TimeStamp Value 053000
M344_01 Set TimeStamp Value 060000
M345_01 Set TimeStamp Value 063000
M346_01 Set TimeStamp Value 070000
M347_01 Set TimeStamp Value 073000
M348_01 Set TimeStamp Value 080000
M349_01 Set TimeStamp Value 083000
M350_01 Set TimeStamp Value 090000
M351_01 Set TimeStamp Value 093000
M352_01 Set TimeStamp Value 100000
M353_01 Set TimeStamp Value 103000
M354_01 Set TimeStamp Value 110000
M355_01 Set TimeStamp Value 113000
M356_01 Set TimeStamp Value 120000
M357_01 Set TimeStamp Value 123000
M358_01 Set TimeStamp Value 130000
M359_01 Set TimeStamp Value 133000
M360_01 Set TimeStamp Value 140000
M361_01 Set TimeStamp Value 143000
M362_01 Set TimeStamp Value 150000
M363_01 Set TimeStamp Value 153000
M364_01 Set TimeStamp Value 160000
M365_01 Set TimeStamp Value 163000
M366_01 Set TimeStamp Value 170000
M367_01 Set TimeStamp Value 173000
M368_01 Set TimeStamp Value 180000
M369_01 Set TimeStamp Value 183000
M370_01 Set TimeStamp Value 190000
M371_01 Set TimeStamp Value 193000
M372_01 Set TimeStamp Value 200000
M373_01 Set TimeStamp Value 203000
M374_01 Set TimeStamp Value 210000
M375_01 Set TimeStamp Value 213000
M376_01 Set TimeStamp Value 220000
M377_01 Set TimeStamp Value 223000

Configuration Symbol Reference List

M378_01	Set TimeStamp Value 230000
M379_01	Set TimeStamp Value 233000
M381_01	Preamble STX
M382_01	Postamble ETX
M383_01	Default to USB with LEDs and Active BT
M384_01	Default to PS/2 with LEDs and Active BT
M385_01	Image Uploader - Compressed Image (JPEG)
M386_01	Image Uploader - Uncompressed Image (BMP)
M387_01	Image Uploader - Far Field
M388_01	Image Uploader - Near Field
M389_01	Code 39 Narrow Margin Disable
M390_01	Code 39 Narrow Margin Enable
M391_01	Code 128 Narrow Margin Disable
M392_01	Code 128 Narrow Margin Enable
M393_01	Code 11 Disable
M394_01	Code 11 Enable (Two Checksum Digits Checked)
M395_01	Code 11 (One Checksum Digit Checked)
M396_01	Code 11 (Two Checksum Digits Checked and Stripped from Result)
M397_01	Code 11 (One Checksum Digit Checked and Stripped from Result)
M398_01	Disable Code 128 Narrow Margin
M399_01	Enable Code 128 Narrow Margin
M400_01	Disable Code 39 Narrow Margin
M401_01	Enable Code 39 Narrow Margin
M402_01	Translate CRLF into Enter
M404_01	Erase Preamble Only
M405_02	Erase Postamble Only
M406_02	Preamble and Postamble
M407_01	Default to Factory Settings, Save Settings, Reboot
M408_01	Disable Pharmacode
M409_01	Enable Pharmacode- No Color, Standard Rules, Horiz. Decode, Normal Direction
M410_01	Enable Pharmacode - Color, Relaxed Contrast, Horiz. Decode, Normal Direction
M411_01	Enable Pharmacode - No Color, Standard Rules, Vert. Decode, Normal Direction
M412_01	Enable Pharmacode - Color, Relaxed Contrast, Vert. Decode, Normal Direction
M413_01	Enable Pharmacode - No Color, Standard Rules, Horiz. Decode, Reverse Direction
M414_01	Enable Pharmacode - Color, Relaxed Contrast, Horiz. Decode, Reverse Direction
M415_01	Enable Pharmacode - No Color, Standard Rules, Vert. Decode, Reverse Direction
M416_01	Enable Pharmacode - Color, Relaxed Contrast, Vert. Decode, Reverse Direction
M417_01	RS-232 Suppress Imager Responses
M418_02	Default to RS-232 Factory Settings
M419_01	RS-232 Enable Imager Responses

M420_01	Replace All \\ with \ for PDF417
M421_01	Set Top Buttons to Toggle Continuous Trigger On and Off
M422_01	RF Attempt to Connect Timeout: Default - 30 sec.
M423_01	RF Attempt to Connect Timeout: 15 sec.
M424_01	USB - Detect Out Endpoint
M425_01	USB - Use Out Endpoint
M426_01	USB - Do Not Use Out Endpoint
M427_01	RF Timeout - 6 hours
M428_01	Unlock Settings (Except Imager ID)
M429_01	Lock Settings
M430_01	Reboot Imager
M432_01	Modem - 1200 baud
M433_01	Modem - 1200 baud
M434_01	Modem - 1200 baud
M435_01	Modem - 1200 baud
M436_01	Modem - 1200 baud
M437_01	Modem - 1200 baud
M438_01	Modem - 1200 baud
M439_01	Modem - 1200 baud
M440_01	Modem - 1200 baud
M441_01	Modem - 1200 baud
M442_01	Modem - 1200 baud
M443_01	Modem - 1200 baud
M444_01	Modem - 1200 baud
M445_01	Modem - 1200 baud
M446_01	Modem - 1200 baud
M447_01	Modem - 1200 baud
M448_01	Modem - 1200 baud
M449_01	Modem - 2400 baud
M450_01	Modem - 2400 baud
M451_01	Modem - 2400 baud
M452_01	Modem - 2400 baud
M453_01	Modem - 2400 baud
M454_01	Modem - 2400 baud
M455_01	Modem - 2400 baud
M456_01	Modem - 2400 baud
M457_01	Modem - 2400 baud
M458_01	Modem - 2400 baud
M459_01	Modem - 2400 baud
M460_01	Modem - 2400 baud

Configuration Symbol Reference List

M461_01	Modem - 2400 baud
M462_01	Modem - 2400 baud
M463_01	Modem - 2400 baud
M464_01	Modem - 2400 baud
M465_01	Modem - 2400 baud
M466_01	Modem - 4800 baud
M467_01	Modem - 4800 baud
M468_01	Modem - 4800 baud
M469_01	Modem - 4800 baud
M470_01	Modem - 4800 baud
M471_01	Modem - 4800 baud
M472_01	Modem - 4800 baud
M473_01	Modem - 4800 baud
M474_01	Modem - 4800 baud
M475_01	Modem - 4800 baud
M476_01	Modem - 4800 baud
M477_01	Modem - 4800 baud
M478_01	Modem - 4800 baud
M479_01	Modem - 4800 baud
M480_01	Modem - 4800 baud
M481_01	Modem - 4800 baud
M482_01	Modem - 4800 baud
M483_01	Modem - 9600 baud
M484_01	Modem - 9600 baud
M485_01	Modem - 9600 baud
M486_01	Modem - 9600 baud
M487_01	Modem - 9600 baud
M488_01	Modem - 9600 baud
M489_01	Modem - 9600 baud
M490_01	Modem - 9600 baud
M491_01	Modem - 9600 baud
M492_01	Modem - 9600 baud
M493_01	Modem - 9600 baud
M494_01	Modem - 9600 baud
M495_01	Modem - 9600 baud
M496_01	Modem - 9600 baud
M497_01	Modem - 9600 baud
M498_01	Modem - 9600 baud
M499_01	Modem - 9600 baud
M500_01	Modem - 19200 baud

M501_01	Modem - 19200 baud
M502_01	Modem - 19200 baud
M503_01	Modem - 19200 baud
M504_01	Modem - 19200 baud
M505_01	Modem - 19200 baud
M506_01	Modem - 19200 baud
M507_01	Modem - 19200 baud
M508_01	Modem - 19200 baud
M509_01	Modem - 19200 baud
M510_01	Modem - 19200 baud
M511_01	Modem - 19200 baud
M512_01	Modem - 19200 baud
M513_01	Modem - 19200 baud
M514_01	Modem - 19200 baud
M515_01	Modem - 19200 baud
M516_01	Modem - 19200 baud
M517_01	Modem - 38400 baud
M518_01	Modem - 38400 baud
M519_01	Modem - 38400 baud
M520_01	Modem - 38400 baud
M521_01	Modem - 38400 baud
M522_01	Modem - 38400 baud
M523_01	Modem - 38400 baud
M524_01	Modem - 38400 baud
M525_01	Modem - 38400 baud
M526_01	Modem - 38400 baud
M527_01	Modem - 38400 baud
M528_01	Modem - 38400 baud
M529_01	Modem - 38400 baud
M530_01	Modem - 38400 baud
M531_01	Modem - 38400 baud
M532_01	Modem - 38400 baud
M533_01	Modem - 38400 baud
M534_01	Modem - 57600 baud
M535_01	Modem - 57600 baud
M536_01	Modem - 57600 baud
M537_01	Modem - 57600 baud
M538_01	Modem - 57600 baud
M539_01	Modem - 57600 baud
M540_01	Modem - 57600 baud

Configuration Symbol Reference List

M541_01	Modem - 57600 baud
M542_01	Modem - 57600 baud
M543_01	Modem - 57600 baud
M544_01	Modem - 57600 baud
M545_01	Modem - 57600 baud
M546_01	Modem - 57600 baud
M547_01	Modem - 57600 baud
M548_01	Modem - 57600 baud
M549_01	Modem - 57600 baud
M550_01	Modem - 57600 baud
M551_01	Modem - 115200 baud
M552_01	Modem - 115200 baud
M553_01	Modem - 115200 baud
M554_01	Modem - 115200 baud
M555_01	Modem - 115200 baud
M556_01	Modem - 115200 baud
M557_01	Modem - 115200 baud
M558_01	Modem - 115200 baud
M559_01	Modem - 115200 baud
M560_01	Modem - 115200 baud
M561_01	Modem - 115200 baud
M562_01	Modem - 115200 baud
M563_01	Modem - 115200 baud
M564_01	Modem - 115200 baud
M565_01	Modem - 115200 baud
M566_01	Modem - 115200 baud
M567_01	Modem - 115200 baud
M568_01	Dump Setting Command
M569_02	Maxicode - Secondary Data Pass Through
M571_01	Append Imager ID to Preamble
M572_01	Append Imager ID to Postamble
M573_01	Append “:” to Preamble
M574_01	Continuous Read - Near and Far Fields - Timeout Uncabled 7 Days - Save Settings
M576_01	Append Symbology to Postamble
M577_01	Save Settings Using “~”
M578_01	Append “:” to Preamble - Serial Mode
M579_02	Illumination Flash On Event
M580_02	Illumination Constant On Event
M581_01	RF Range Notification Off
M582_01	RF Range Notification - Vibrate

M583_01	RF Range Notification - Beep
M584_02	USB Kb Enumerate on Preset LED - Disable Alternate OS Compatibility
M585_02	USB Kb Enumerate on Preset LED - Enable Alternate OS Compatibility
M586_01	Default to Factory RF One-Way Settings
M587_01	RF Range Notification - Beep and Vibrate
M589_01	Tab Keystroke
M590_01	PS/2 Modem - English Keyboard Map with Leading 0 for Non-Printable ASCII
M591_01	PS/2 Modem - Universal Keyboard Map when in RF Mode
M592_01	PS/2 Modem - Custom Keyboard Map
M593_01	PS/2 Modem - English Keyboard Map without Leading 0 for Non-Printable ASCII
M594_01	PS/2 Modem - French Keyboard Map
M595_01	PS/2 Modem - German Keyboard Map
M596_01	PS/2 Modem - Japanese Keyboard Map
M597_01	PS/2 Modem - Ctrl + Char. for Non-Printable ASCII
M598_01	USB Polling Speed - 10 mS
M599_01	USB Polling Speed - 20 mS
M600_01	USB Polling Speed - 30 mS
M602_01	US English Keyboard Map without Leading 0 in Alt + Num for Non-Printable ASCII
M603_01	French Keyboard Mapping
M604_01	German Keyboard Mapping
M605_01	Japanese Keyboard Mapping
M606_01	US English Keyboard with Ctrl + Char. for Non-Printable ASCII
M607_01	Full Field Image Capture (1280 x 1024)
M608_01	Duplicate Read Delay - 300 sec.
M609_03	Enable Micro QR Code
M610_01	Show Bluetooth Access in Modem
M658_01	AGC Enable Version 1
M659_01	AGC Enable Version 0 (Legacy)
M661_01	Enable RS-232 Bluetooth Mode
M667_01	Enable QR Code and Micro QR Code
M668_01	USB Virtual COM Port One-Way Mode
M669_01	USB Virtual COM Port Two-Way Mode
M670_01	Trioptic Code 39 Off
M671_01	Trioptic Code 39 On
M672_01	NEC 2 of 5 Off
M673_01	NEC 2 of 5 On
M674_01	Matrix 2 of 5 Off
M675_01	Matrix 2 of 5 On
M684_01	RF Factory Defaults
M685_01	Interleaved 2 of 5 with Control Character Stripped from Result

Configuration Symbol Reference List

M687_03	Enable Micro QR Code Standard and Inverse
M692_01	Boot Mode
M693_01	PS/2 Interscan Delay - 5 mS
M694_01	PS/2 Interscan Delay - 10 mS
M695_01	PS/2 Interscan Delay - 100 mS
M696_01	Clear All JavaScript Files
M701_01	Enable Motion Detection - Near and Far Fields
M702_01	Disable Motion Detection (Default)
M704_01	Disable Bluetooth Connection While Charging
M705_01	Enable Bluetooth Connection While Charging
M706_02	Enable Time Stamp: Battery-Powered Time Clock Preamble
M707_03	Disable Time Stamp: Battery-Powered Time Clock Preamble
M708_01	USB Bluetooth Mode
M710_02	Lockout Link Mode
M711_01	Unlock Link
M738_01	Enable Background Capture
M739_01	Disable Background Capture
M742_01	Modem Pre-emptible
M743_01	Modem Non-Pre-emptible
M744_01	Enable Data Matrix Decode Improvements for Low Contrast/Binarization
M745_01	Disable Data Matrix Decode Improvements for Low Contrast/Binarization
M746_01	Enable Auto-Save Last Bluetooth Address
M747_01	Disable Auto-Save Last Bluetooth Address
Q001_01	Enable Left Button Mode Switching (Quadrus Only/Standard)
Q002_01	Change IP Mode - Quadrus Only Mode (Default)
Q003_01	Change IP Mode - Quadrus Mode 1
Q004_01	Change IP Mode - Standard Mode
Q005_01	ECC 0-140 On
Q006_01	ECC 0-140 Off
Q007_01	Default LEDs
Q008_01	IR LEDs Off, Visible LEDs On
Q009_01	Visible LEDs Off, IR LEDs On (Near Field IR LEDs Off)
Q010_01	Control IR LEDs Separately (Lower Intensity IR)
Q011_01	Disable Left Button
Q012_01	Disable Right Button
Q013_01	Disable Left and Right Buttons
Q014_01	UII-Only Enabled
Q015_01	UII-Only Enabled with Error Messaging
Q016_01	UII Enabled with Pass Through
Q017_01	UII Enabled with Error Messaging and Pass Through

Q018_01	UII Disabled
Q019_01	Enable 2-Symbol Simultaneous Read
Q020_01	Disable 2-Symbol Simultaneous Read
Q021_01	Laser Off, Visible LEDs Off, IR LEDs On at 100%
Q022_01	Laser On, Visible LEDs Off, IR LEDs On at 100%
Q023_01	Laser Off, All LEDs On at 100%
Q024_01	Laser On, All LEDs On at 100%
Q025_01	Enable USB Battery Charge Mode
Q026_01	Default to Previous Settings (Disable USB Battery Charge Mode)
Q027_01	Laser Off, Control IR Separately in Both Fields
Q028_01	Laser On, Control IR Separately in Both Fields
Q029_01	RS-232 Connect Mode
Q030_01	USB Connect Mode
Q031_01	Enable MIL-STD-130M
Q032_01	Enable MIL-STD-130N
MS101_01	RS-232 Default Settings Mode

Appendix E — Performing a Hardware Default and Manual Battery Recharge

Note: The following procedures are only applicable to MS-Q configurations using the original (H1) handle and original lithium ion battery.

Occasionally it may become necessary to reset your imager to its factory default configuration. If your imager is locked or is failing to read, perform the following steps:

1. Remove the imager from the H1 handle.



2. Disengage the USB or RS-232 cable from the bottom of the H1 handle.

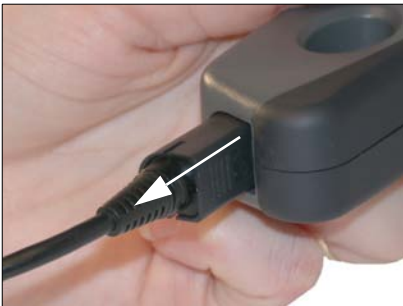

Important: Do not pull directly on the cable; grasp and pull on the connector housing to release the locking mechanism and disengage.

3. Remove the battery.



Note: If you are using a battery blank, you do NOT need to remove it when performing a hardware default.

(Continued on next page)

- Press and hold down the **left** and **right** top buttons while reinserting and locking the battery.

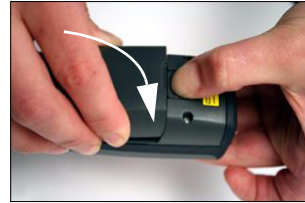
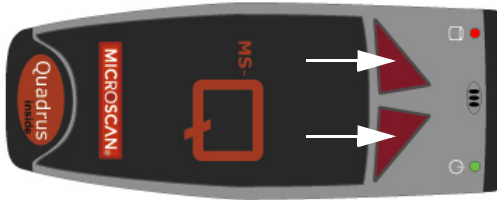

- Reinsert the imager in the handle attachment's cradle, aligning the cradle with the grooves along the sides of the main unit. Be sure that the handle's 8-pin mini-DIN connector inserts completely into the back of the imager.



- Press and hold down the imager's **left** and **right** top buttons while reinserting the cable into the bottom of the handle attachment.



Important: For the default process to work correctly, you must release both buttons as soon as the left indicator LED switches off.

- When the cable is fully inserted, the imager will beep five times. The left indicator LED will be **RED** and the right indicator LED will be **GREEN**.

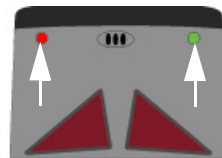

- Press and hold down both the **left** and **right** top buttons until the left indicator LED switches off.

The imager will then cycle through several different LED patterns and emit **two beeps**. This indicates that the imager is in its default mode and is ready for use. Be sure that the imager's memory is clear before you return to your desired settings. The following symbols will allow you to clear the imager's memory of commands, settings, XML rules, and other data:



Clear XML Rules

M052_01



Clear Memory

M050_01

Performing a Manual Battery Recharge

If the MS-Q's lithium ion battery is allowed to lose 100% of its charge, the imager will become locked in a continuous vibration cycle. The mechanism of vibration is the same as the "successful decode" indicator, which can be switched between **beep** and **vibrate**. However, when the imager vibrates to indicate total loss of battery charge, it is unable to decode symbol data and it cannot be defaulted.

The following procedure provides enough charge to "jump-start" the imager and perform a hardware default.

1. Remove the battery.



2. Align the battery with its housing on the side opposite the sliding latch mechanism.

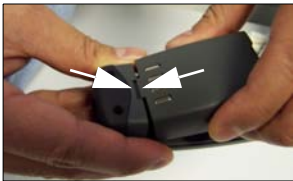

Hold the battery at an angle from its housing, balanced where the battery's tab is aligned with the housing's slot.

3. Starting from the angled position described in step 2, lower the battery completely into its housing **three times**, but *do not engage the sliding latch mechanism until the third time the battery is inserted*.



The battery should be inserted for slightly less than one second each time it is lowered. Maintain a steady rhythm while performing this sequence.

4. The third and final time the battery is lowered and inserted, leave it in its housing and move the sliding latch mechanism into its locked position.
5. Default the imager. (See [Performing a Hardware Default and Manual Battery Recharge](#) on page A-58.)

Note: For best results, charge the battery fully before you next use the imager.

Appendix F — MS-Q Quadrus Secure with Image Lock

The MS-Q Quadrus Imager is available in a secured version with disabled image capture and downloading. Permanent removal of image upload functionality in the MS-Q Quadrus Secure with Image Lock (FIS-6100-0046G – Rev 5 Hardware or earlier; FIS-6100-0053G – Rev 6 Hardware) makes it useful in sensitive industrial environments where photography is prohibited.



Important: The MS-Q Quadrus Secure’s Image Lock function cannot be “turned off”; it is a permanent part of the imager’s feature set.

Note: The MS-Q Quadrus Secure with Image Lock is available with USB connectivity. Contact your Microscan sales representative for further product details.

Appendix G — MS-Q Protective Jacket

The MS-Q Protective Jacket (20-000925-01) is an accessory for MS-Q Imagers with the first-generation (H1) handle option. This accessory is a cost-effective way to upgrade the protection of the MS-Q for rugged industrial environments in the following ways:

- Provides inexpensive insurance against accidental drops or other potentially damaging contact events on the factory floor
- Triples the drop shock protection to the main body of the imager
- Shields LEDs and optics with extended front guard

Contact your Microscan sales representative for further accessory details.

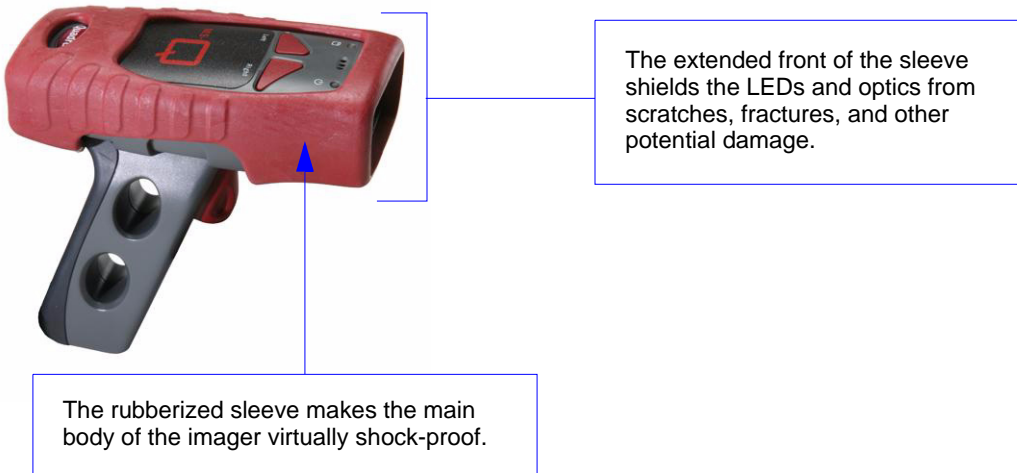

Note: The MS-Q Protective Jacket is only available with the original (H1) handle option.

Appendix H — MS-Q Battery Charger

The MS-Q Battery Charger Kit can be used with the battery handle option.

Battery Charger Kit



Battery Charger Kit (as pictured) includes:

- (1.) Power Supply
- (2.) Charger, Retainer Clip, screw, washer
- (3.) 4 screws (for Bluetooth Modem)

Note: Battery Handle, Reader, Bluetooth Modem, and cable ordered and sold separately.

Battery Charger Installation Instructions

Installing the Power Cable

1. Connect the power supply to the charger by aligning the connector on the power supply to the power connector on the bottom of the charger.



Step 2



Step 3

2. Firmly press the power supply connector and the charger's power connector together.
3. Guide the power cable through the space provided on the end of the charger, as shown above.

Installing the Modem

The charger is shipped with four screws for attaching a Bluetooth Modem.

1. Turn the charger over so that the base faces upward.
2. Place the Bluetooth Modem into the charger with the 8-pin DIN connector facing away from the battery charging connectors.



Step 3



Step 4

3. Secure the modem with the four screws provided.
4. Attach the cable to the modem by aligning the 8-pin DIN connectors and pushing them together firmly.
5. Guide the cable through the opening at the end of the charger that is aligned with the 8-pin DIN connector.

Battery Charger Mounting Instructions

The charger can be mounted to a wall or a countertop.



**Wall-Mounted
Battery Charger**



**Countertop-Mounted
Battery Charger**

Note: If you are mounting the charger to a wall, first install the retainer clip with washer and screw (**Step 1**). The retainer clip prevents the handle from detaching from the charger and falling. If you are mounting the charger to a countertop, start at Step 2 and do not install the retainer clip.

1. From the back of the charger, slide the retainer clip into the slot provided. Secure the retainer clip with the washer and screw provided.



Step 1



Step 1 (cont.)



Step 3

2. Secure the charger to the wall or countertop with screws of the appropriate size.

Note: Screws for mounting the assembled charger should not exceed 0.2" on the shaft or 0.4" on the head. Mounting screws not included in assembly kit.

3. Rest the top of the handle in the top slot and gently slide the bottom of the handle onto the charging pins.

MS-Q Battery Charger Options

Kit, 2-Bay Battery Charger for H1 Batteries, USA Power Supply	98-000075-04
Kit, 2-Bay Battery Charger for H1 Batteries, Europe Power Supply	98-000075-05
Kit, 2-Bay Battery Charger for H1 Batteries, UK Power Supply	98-000075-06
Kit, Cable Battery Charger for Battery Handle, USA Power Supply	98-000075-07
Kit, Cable Battery Charger for Battery Handle, Europe Power Supply	98-000075-08
Kit, Cable Battery Charger for Battery Handle, UK Power Supply	98-000075-09
Kit, Charging Bay for Battery Handle, USA Power Supply	98-000075-10
Kit, Charging Bay for Battery Handle, Europe Power Supply	98-000075-11
Kit, Charging Bay for Battery Handle, UK Power Supply	98-000075-12
Kit, Charging Bay for Battery Handle, No Power Supply	98-000075-13

Appendix I — MS-Q Bluetooth Modem

The MS-Q Bluetooth Modem is an external modem designed to be connected to the host computer while using a Bluetooth-enabled MS-Q Imager. The modem enables the imager to transmit captured and decoded data wirelessly to the host computer. The modem can accommodate three different cable attachment types, as shown below.



**Bluetooth Modem
with Cable**

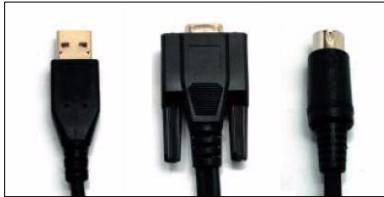

USB RS-232 PS/2

Bluetooth Modem Installation with USB Cable

Install Cable

- Attach the USB cable to the Bluetooth Modem.



- Connect the USB connector to the host computer. The modem's blue light will illuminate when connected.



Read Quick Connect Code

- Read the **Quick Connect Code** on the Bluetooth Modem's top label.

Note: A Quick Connect Code can also be created in **ESP's Utilities** interface.

Establish Mode

- Read the **USB Bluetooth Mode** symbol below.



USB Bluetooth Mode

M708_01

Connecting with a Quick Connect Code (All Cable Types)

- Read the **Quick Connect Code** on the top label of the Bluetooth Modem, using the MS-Q Imager you intend to connect to the host computer.

The imager and host computer should connect within 60 seconds. The MS-Q will beep once and flash both LEDs **GREEN** as a confirmation.

If the MS-Q and host computer do not connect, the imager will beep three times in rapid succession and flash its **RED** LEDs.

Modem Firmware Version

- Read the symbol below to check the Bluetooth Modem’s firmware version.



Firmware output will be in the following format: MSP430 firmware version; TUSB firmware version; 1-digit comm. mode (0 = PS/2, 1 = Serial, 3 = USB Keyboard); 1-digit keyboard mapping value; 1-digit packet protocol value.

Bluetooth Modem Installation with PS/2 Cable

Install Cable

- Attach the PS/2 cable to the Bluetooth Modem.
- Detach the keyboard from the host computer and connect it to the PS/2 cable, as shown below.
- Connect the other end of the PS/2 cable to the host computer, as shown below.



Note: The modem is powered by the PS/2 port, and so does not require a separate power supply. The modem’s blue light will illuminate when connected.

Read Quick Connect Code

- Read the **Quick Connect Code** on the Bluetooth Modem’s top label.
- Note:** A Quick Connect Code can also be created in **ESP’s Utilities** interface.

Establish Mode

- Read the **PS/2 Bluetooth Mode** symbol below.



You are now ready to begin sending decoded symbol data to the host.

Keyboard Input (USB and PS/2)

The Bluetooth Modem is set to English-language keyboard mapping by default. To communicate using a different keyboard setting, read the appropriate configuration symbol below.



M590_01
**English
(Default)**



M591_01
Universal



M594_01
French



M595_01
German



M596_01
Japanese



M593_01
**No
Leading
0**



M597_01
**Ctrl +
Char.**

Bluetooth Modem Installation with RS-232 Cable

Install Cable

- Attach the RS-232 cable to the Bluetooth Modem.
- Connect the RS-232 adapter to the back of the host computer.
- Connect the RS-232 cable to the power supply.
- Plug the power supply into a wall socket.



Read Quick Connect Code

- Read the **Quick Connect Code** on the Bluetooth Modem's top label.

Note: A Quick Connect Code can also be created in **ESP's Utilities** interface.

Establish Mode

- Read the **RS-232 Bluetooth Mode** symbol at right.

Change Baud Rate Setting

- Read the appropriate symbol below to set the desired Baud Rate.

Note: These symbols only affect Baud Rate settings for the modem. They have no effect on Baud Rate settings in the MS-Q.



M313_01
1200



M314_01
2400



M315_01
4800



M316_01
9600 (Default)



**RS-232
Bluetooth
Mode**

M661_01

RS-232 Bluetooth Modem Defaults:

Baud Rate: 9600
Data Bits: 8
Parity: None
Stop Bits: 1
Hardware: None

You are now ready to begin sending decoded symbol data to the host, using any open software application that accepts serial data.

Appendix J — MS-Q Maintenance

MS-Q maintenance guidelines are provided below.

Cleaning the MS-Q Window

The MS-Q window should be clean to allow optimum performance. The window is the clear plastic piece inside the front of the reader. Do not touch the window, as fingerprints may impede decode performance. The MS-Q uses CMOS technology that is much like a digital camera, and marks on the window will interfere with image captures.

If the window becomes dirty, clean it with a soft, non-abrasive cloth or a facial tissue (no lotions or additives) that has been moistened with water. A mild detergent may be used to clean the window, but the window should be wiped with a water-moistened cloth or tissue after using the detergent. The MS-Q housing may be cleaned in the same way.

For applications that require cleaning with disinfectant, please use products with the following ingredients:

- Isopropyl Alcohol
- Ethyl Alcohol (Denatured Grade)

Do not use bleach.

Hyperlink Index

A

- About the MS-Q Imager
- About This Manual
- Adaptive Mode
- Add Batch Files to Collection
- Add Macro
- Advanced
- Advanced Operations
- Advanced Options
- Advanced Preferences
- AGC Frame Adjust Count
- AGC Selection
- AI (Format 05)
- Always Ask Before Auto Sync Occurs
- Appendices
- Application Mode
- Assemble the Imager
- Assembling the Imager with a BH1 or BH2 Battery Handle
- Assembling the Imager with an H1 (Original) Handle
- Assembling the Imager with the H2 Cabled Handle
- Assembly (100 Series)
- Assembly (200 Series)
- Auto Transfer Buffer Memory
- Auto White Balance
- Automatic Gain Control (AGC)
- Auto-Save Last Bluetooth Address
- Aztec
- Aztec by ESP

B

- Background Bluetooth Connection
- Bar Code Options Preferences
- Barcode Dialog
- Basic Operations
- Batch Mode Indicators
- Batch Mode Options
- Batch Setup
- Batch/Battery Communication Indicators
- Batch/Battery Communications
- Batch/Battery Configuration

C

- Batch/Battery Hardware
- Batch/Battery Interface
- Batch/Battery Overview
- Battery Charge Times (Typical)
- Battery Handle (3900 mAH) Parts List
- Battery Usage (Typical)
- Baud Rate (RS-232)
- Beep / Vibrate
- Beep and Vibrate Settings
- Beep and Vibrate Settings by ESP
- Beep Before Bluetooth Connection
- Beep Volume
- Begin Transmission
- BH1 / BH2 Charger Installation Instructions
- BH1 / BH2 Charger Kit
- BH1 / BH2 Charger Mounting Instructions
- Bluetooth
- Bluetooth Access
- Bluetooth Access by ESP
- Bluetooth Auto-Connect
- Bluetooth by RS-232
- Bluetooth by USB
- Bluetooth Communication Indicators
- Bluetooth Communications
- Bluetooth Configuration
- Bluetooth Hardware
- Bluetooth Interface
- Button Stay-Down Time
- Button/Trigger Confirmation Time

C

- Capture Text
- CE Standards
- Change Background Color
- Change Echo Font
- Change Font
- Change Keyboard Macros
- Check Required Hardware
- Clear
- Clear All Data
- Clear XML Rules
- Codabar
- Codabar by ESP
- Codablock by ESP

D

- Codablock F
- Code 11
- Code 11 by ESP
- Code 128
- Code 128 by ESP
- Code 39
- Code 39 by ESP
- Code 93
- Code 93 by ESP
- Communication Protocols
- Communications
- Communications by ESP
- Communications Overview
- Complete Configuration
- Compliance Indicator
- Composite
- Composite by ESP
- Composite Linkage Control
- Configuration Symbol Reference List
- Configuration Symbols
- Connect
- Connecting to the Bluetooth Modem
- Connecting to the Bluetooth Modem via RS-232
- Connecting via RS-232 with a USB Bluetooth Modem
- Connection Wizard
- Construct 1
- Construct 2
- Continuous Illumination
- Continuous Operations
- Continuous Read
- Continuous Read, Duplicate Read Delays
- Continuous Read, Sleep Timeout
- Continuous Read, Trigger Delays
- Continuous Trigger Optimization
- Continuous Trigger Programming
- Copy

D

- Data Bits (RS-232)
- Data Element Separator
- Data Matrix
- Data Matrix by ESP
- Data Matrix ECC 0-140
- Data Matrix Improvements

E

- Deactivate XML Rules
- Decode Try Time
- Default Reader
- Default Settings
- Defaulting ESP Settings
- Delete Data
- Delete Stored Errors
- Delete Stored Results
- Determine Optimum Position
- Device Control
- DI (Format 06)
- Differences from Default
- Disable Echo
- Disable Right Button
- Disclaimer
- Disconnect Bluetooth
- Display Incoming Data Even When Not in Focus
- Do Not Send or Receive Settings
- Document Memo
- Download Batch File Collection
- Dual Optics

E

- Edit
- Edit Macro
- Editing a Macro
- EID Too Long
- Electrical
- Electrical Specifications
- Enable Echo
- Encoding a UII
- Enhanced Format
- Entering Magic Sequence
- Enterprise Identifier (EID)
- Environmental Specifications
- Error Messaging
- ESP Optimization Matrix
- ESP System Requirements
- Expect Host Response
- EZ Mode

F

- FCC
- Find

G

Find Next
Find Previous
Firmware
Firmware Verification
FIS Options
Fixed Mode
Format Header
Function Keys

G

Gain Break Point
General Preferences
General Specifications
Generate Barcode
Global Optimization
GS1 DataBar
GS1 DataBar by ESP

H

H1 (Original) Handle Parts List
H2 Cabled Handle Parts List
Handle Trigger
Handle Trigger Optimization
Handle Trigger Programming
Handle Trigger Take Picture
Highlighting
Host Acknowledgement Timeout

I

I/O Parameters
I/O Parameters by ESP
Illumination
Image Output options
Image Transform
Image Upload
Imager ID
Import / Export
Indicators
Install ESP
Installation Steps for Batch/Battery
Installation Steps for Bluetooth
Installation Steps for PS/2

K

- Installation Steps for RS-232
- Installation Steps for USB
- Interleaved 2 of 5
- Interleaved 2 of 5 by ESP
- Invalid AI
- Invalid Characters
- Invalid Compliance Indicator
- Invalid DI
- Invalid Format Header
- Invalid TEI
- IP Modes
- IR LEDs
- Issuing Agency Code

K

- Keyboard Macros
- Keyboard Mapping
- Keyboard Mapping by ESP

L

- Laser Target
- Laser Target Brightness
- Laser Target by ESP
- Laser/LED Radiation
- Left / Right Top LEDs
- Left Button
- Left Button Optimization
- Left Button Programming
- Left/Right LEDs
- Light Collection Options
- LightRay Accessory Options
- LightRay Assembly (100 Series)
- LightRay Assembly (200 Series)
- LightRay Optics
- LightRay Optics by ESP
- LightRay Optics FIS Options
- LightRay Setup
- Limitation of Liability
- Lockout Link Mode (Bluetooth)
- Log Only Mode
- Lower Case Characters

M

Macro Name
Macro Value
Macros
Manual Battery Recharge
Matrix 2 of 5
Matrix 2 of 5 by ESP
Max Connection Wait Time
Maxicode
Maxicode by ESP
Maximum Decodes per Read
Maximum Exposure
Maximum Gain
Mechanical Specifications
Menu Toolbar
Message Trailer
Micro PDF417
MicroPDF417 by ESP
Minimum Exposure
Minimum Gain
Mirroring
Model
Model Memo
Motion Detection
Motion Detection by ESP
Motion Sensitivity
Move to Start
MSI Plessey
MSI Plessey by ESP
MS-Q + LightRay Kits
MS-Q Battery Charger
MS-Q Battery Charger Options
MS-Q Imager
MS-Q Imager Dimensions
MS-Q Operational Feedback
MS-Q Protective Jacket
MS-Q Quadrus Secure with Image Lock

N

Near/Far Fields
NEC 2 of 5
NEC 2 of 5 by ESP
New ESP File

O

- New Model
- Next Row
- Non-Printable Characters
- Non-UII Characters
- Non-UII Characters in a UII Message Stream

O

- One-Way Mode Options
- Only Show Icon
- Only Show Text
- Open / Save
- Optimization Definitions
- Optimization Guide
- Optimization Parameters
- Options
- Other Communications Settings in ESP
- Out-of-Range Notification (Bluetooth)

P

- Parity (RS-232)
- Part Number
- Part Number Too Long
- Paste
- Pause
- PDF417
- PDF417 by ESP
- Performing a Hardware Default
- Pharmacode
- Pharmacode by ESP
- Postal Symbologies
- Postal Symbologies by ESP
- Postamble
- Practice Targeting
- Preamble
- Preamble and Postamble by ESP
- Private Access
- Product Labels
- PS/2 Communications
- PS/2 Configuration
- PS/2 Interface
- PS/2 Keyboard Mode
- PS/2 Mode

Q**Q**

QR Code
QR Code by ESP
Quadrus Mode 1
Quadrus Only Mode
Quick Start

R

Read Parameters
Reader Packet Format
Reader Send Retry Count
Reader to Host Packet Size
Reading Symbols (100 Series)
Reading Symbols (200 Series)
Reading Symbols with LightRay (100 Series)
Reading Symbols with LightRay (200 Series)
Reboot Reader
Receive After Connect
Receive Reader Settings
Receive Settings from the Reader
Reconnect Timeout
Reconnecting to the Host
Rectangular Data Matrix
Region of Interest
Reload Last File
Remove Batch Files from Collection
Remove Macro
Resolution
Restore LEDs (Default)
RF One-Way Mode (Maximum Range)
RF One-Way Mode (Maximum Reliability)
RF Two-Way Mode
Right Button
Right Button Optimization
Right Button Programming
Right Button Take Picture
RS-232 Batch Features
RS-232 Cable Pinouts
RS-232 Communications
RS-232 Configuration
RS-232 Connect Mode
RS-232 Hardware
RS-232 Interface

S

RS-232 Mode
RS-232 Protocol

S

Safety Certifications
Save
Save Batch File Collection As
Save Current Text
Save to Reader
Scanner Indicators
Select Adaptive or Fixed Mode
Select All
Select Model
Select Protocol and Connect to Imager
Select Quadrus Only or Standard Mode
Select Region of Interest
Send
Send and Buffer
Send and Buffer Mode
Send and Log
Send and Log Mode
Send and Save
Send Current Command
Send Current View
Send ESP Settings to the Reader
Send XON with Auto-Connect
Send, No Save
Send/Receive
Serial Number
Serial Number Too Long
Set Decode Time
Set Targeting Zone Tolerances
Settings / Options
Shared Access
Show Both Icon and Text (Default)
Show Connect Prompt
Show Model Prompt
Show Non-Printable Characters
Sizing Information
Skip EZ Mode
Sleep Mode Timeout
Space in Data Qualifier
Standard Mode
Statement of Agency Compliance

- Stop
- Stop Bits (RS-232)
- Store If Not Connected
- Switch Model
- SXGA (Megapixel) Imaging Area
- Symbol Background
- Symbol Density
- Symbol Readability Index
- Symbologies
- Symbologies by ESP
- Symbology Identifier
- Symbology Identifier by ESP

T

- Table of Contents
- Target Spot Brightness
- Targeting Suggestions
- Technical Support
- TEI (Format DD)
- Terminal
- Terminal Dropdown Menu
- Terminal Preferences
- Terminal Right-Click Menu
- Terminal View
- Text Commands
- Text Commands by ESP
- Timeout Settings (Cabled)
- Toggling Between Adaptive and Fixed Modes
- Trailer Character
- Transfer All Data
- Transfer All Data in Memory
- Transfer New Data
- Transferring and Deleting Data
- Tree Controls
- Trigger and Button Programming
- Trigger Character
- Trigger Optimization
- Trigger Optimization by ESP
- Trigger/Button Configuration
- Trigger/Button Summary

U

- UII Disabled (Default)
- UII Elements

V

- UII Enabled with Error Messaging and Pass Through
- UII Enabled with Pass Through
- UII Error Messages
- UII Mode Features
- UII Mode Settings
- UII Mode Settings by ESP
- UII Overview
- UII Too Long
- UII-Only Enabled
- UII-Only Enabled with Error Messaging
- Unique Item Identifiers
- UPC/EAN/JAN
- UPC/EAN/JAN by ESP
- Upload Logged Errors
- Upload Stored Data
- USB Battery Charge Mode
- USB Cable Pinouts
- USB Communications
- USB Configuration
- USB Connect Mode
- USB Downloader Mode
- USB HID POS (Terminal ID 131)
- USB Interface
- USB Keyboard Mode
- USB Native Two-Way Mode
- USB Protocol
- USB Virtual COM Mode
- Using ESP
- Utilities

V

- Valid Formats
- Valid UII Message Streams and UII Output
- VGA and Megapixel Settings
- VGA Imaging Area
- Vibrate/Beep
- View
- Visible LEDs Off and IR On

W

- Warning and Caution Summary
- Warranty Statement